

## ACS-50 Control Panel for UltraTough



### **ALBANY DOOR SYSTEMS**

975-A Old Norcross Road  
Lawrenceville, Ga 30045  
1080 Maritime Drive  
Port Washington, WI 53074  
262-268-9885 Tel  
262-268-9895 Fax  
[www.albanydoors.com](http://www.albanydoors.com)

## Table of Contents

ACS-50 Controller Specifications.....	3
ACS-50 Electrical Practices .....	4
ACS-50 Motherboard Layout .....	6
Wiring to Panel .....	9
Incoming Power .....	9
Voltage Selector (J2).....	9
Pneumatic safety edge (if equipped) .....	9
Electric Edge Connection (if equipped) .....	9
Ground Bar.....	9
Wiring Of The Motherboard .....	9
Table 1 - Mother Board Terminal Wiring .....	10
ACS-50 Settings And Electrical Startup .....	11
CPU Card Switch Settings .....	11
(SW2) Rotary Selector Switch for Closing Time.....	11
TABLE 2 – SW2 Settings .....	11
Jumper J1- Bottom Edge Selector.....	11
Setting of Opening and Closing Functions .....	12
Table 3– Setting of Opening and Closing Functions.....	12
Table 4 – LED Indication of the CPU Card .....	13
Micro switch .....	14
Contact point.....	14
Limit Switch Coarse Adjustment .....	15
Turning on the Door Controller .....	15
Phase Check .....	15
Hold-to-Run-Function.....	16
Input Device Check.....	16
Runtime Monitoring.....	16
Limit Switch Fine Adjustment .....	16
Safety Circuit Limit Box (GFA Drives Only).....	17
Photocell Cut-off (GFA Drives Only).....	17
Inertia Brake Wiring (if Equipped) .....	17
Wiring Schematics: .....	17
WD501-GF002 – ACS50 GFA Operator Wiring 1-Speed.....	18
WD501-GF001 - ACS50 GFA Operator Wiring 2-Speed .....	19
WD502-0000-1 = Door Control Wiring and Electric Edge .....	20
WD503-PC000 = Reversing Photocell Wiring .....	21
LCASC50 = Blanking Light Curtain Photocell Wiring .....	22
WD502-0000A = Interlocking two ACS50 Units .....	24
Troubleshooting .....	25
Table 5- Controller Faults .....	25
Control Panel Replacement Parts.....	26

## ACS-50 Controller Specifications

ACS50 SPECIFICATIONS	VALUES
SUPPLY VOLTAGE:	<b>208VAC NOT AVAILABLE</b> 215-240VAC 3-PHASE 440-480 VAC 3-PHASE 575-600 VAC 3-PHASE
MAXIMUM CURRENT:	10 AMPS
TEMPERATURE, MINIMUM:	-4 F , -20 C
TEMPERATURE, MAXIMUM:	+131 F , +55 C
ENCLOSURE PROTECTION CLASS:	NEMA 1, 3R, 4, 12 AND 13 NOTE: 4X STAINLESS OPTIONAL
DIMENSIONS:	11.8"W X 15.75"H X 8.25" DEEP
WEIGHT:	24 LBS

### **WARNING**

***A SEPERATE 10 AMP FUSED DISCONNECT IS REQUIRED FOR PROTECTION OF THE DRIVE AND CONTROL SYSTEM. THIS DISCONNECT IS TO BE SUPPLIED BY OTHERS. THE DISCONNECT PROVIDED ON THE CONTROL BOX IS NON-FUSED.***

## **WARNING**

**DO NOT INSTALL, OPERATE, OR SERVICE THIS PRODUCT UNLESS YOU HAVE READ AND UNDERSTAND THE SAFETY PRACTICES, WARNINGS, INSTALLATION, AND MAINTENANCE INSTRUCTIONS CONTAINED IN THIS MANUAL.**

### ACS-50 Electrical Practices

1.

1. Insert a mini screwdriver in the operating slot, located on the top of the terminal, up to the stop.
2. The screwdriver blade holds the clamping spring open automatically so that the conductor can be introduced into the clamping unit
3. Insert the wire into the block.
4. Withdraw the screwdriver – the conductor is automatically clamped.

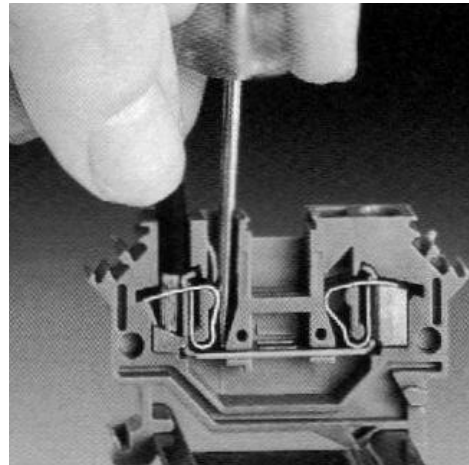

## **WARNING**

**ALL CONDUIT PENETRATIONS INTO THIS CONTROL PANEL MUST BE FROM THE BOTTOM. TOP PENETRATIONS WILL VOID WARRANTY.**

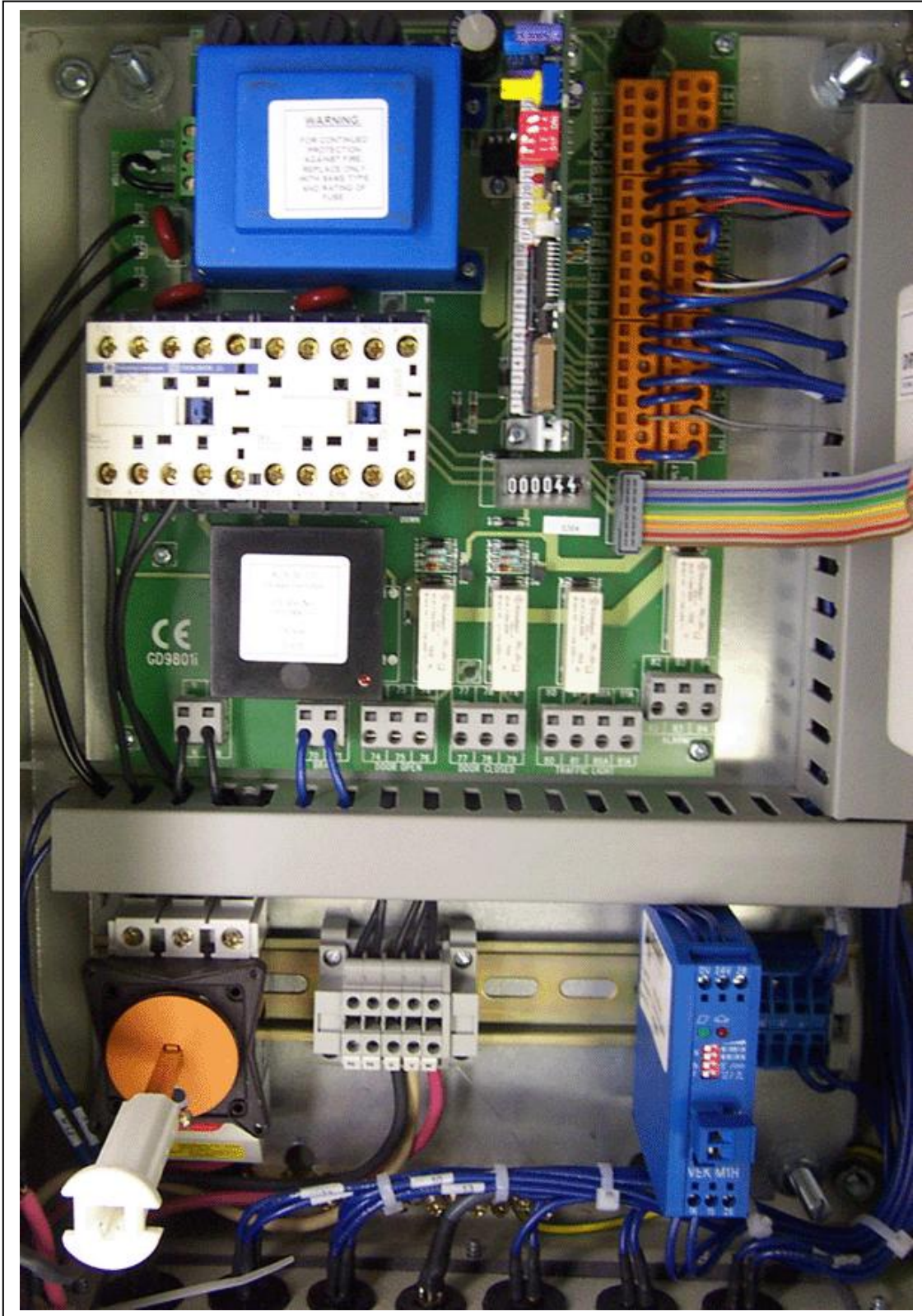

**The ACS50 Control Panel Interior (Single speed)**

## ACS-50 Motherboard Layout

The following refers to the layout of the motherboard inside the ACS 50 control box:

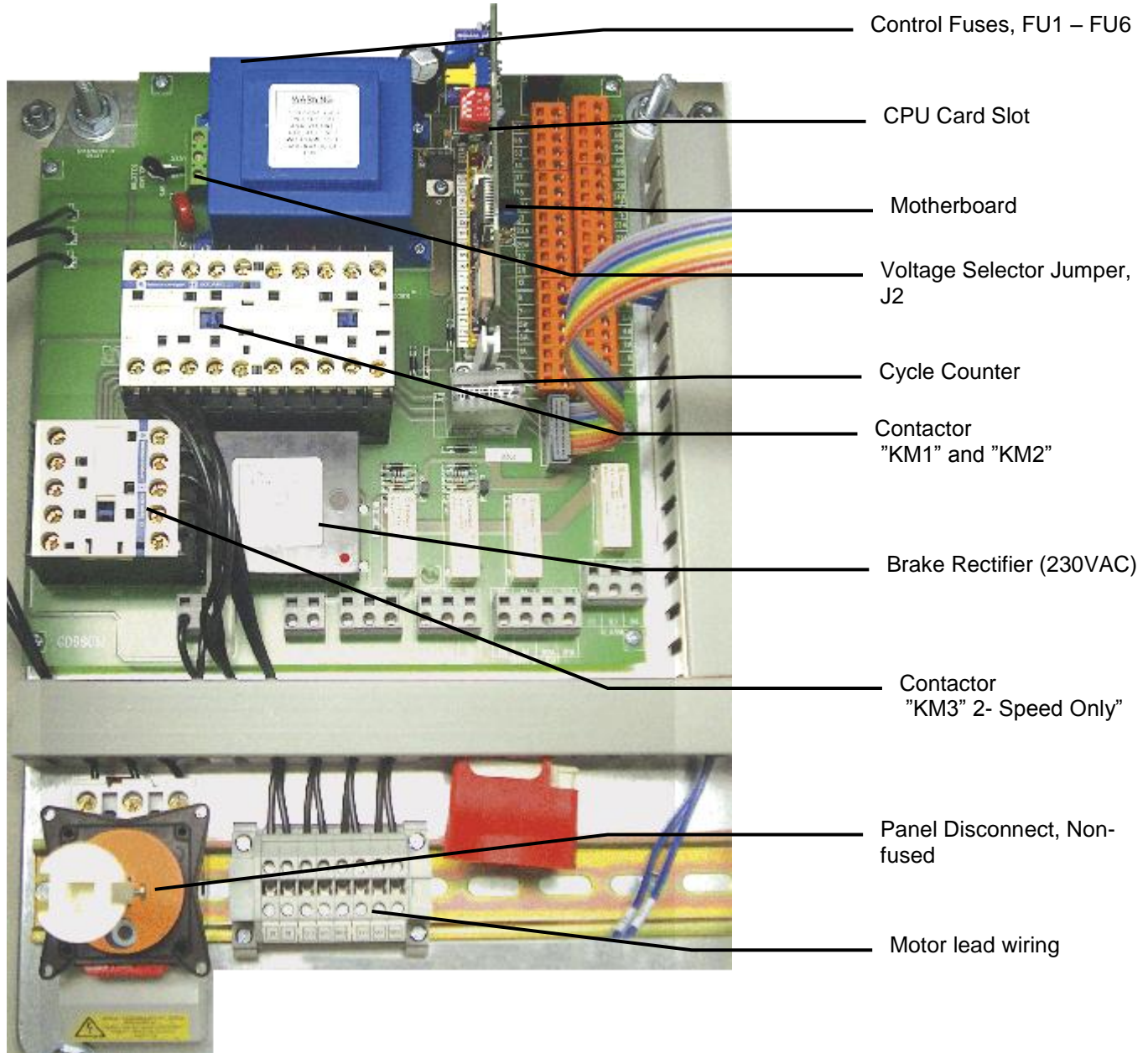

## The ACS50 Control Panel Interior (Two speed)

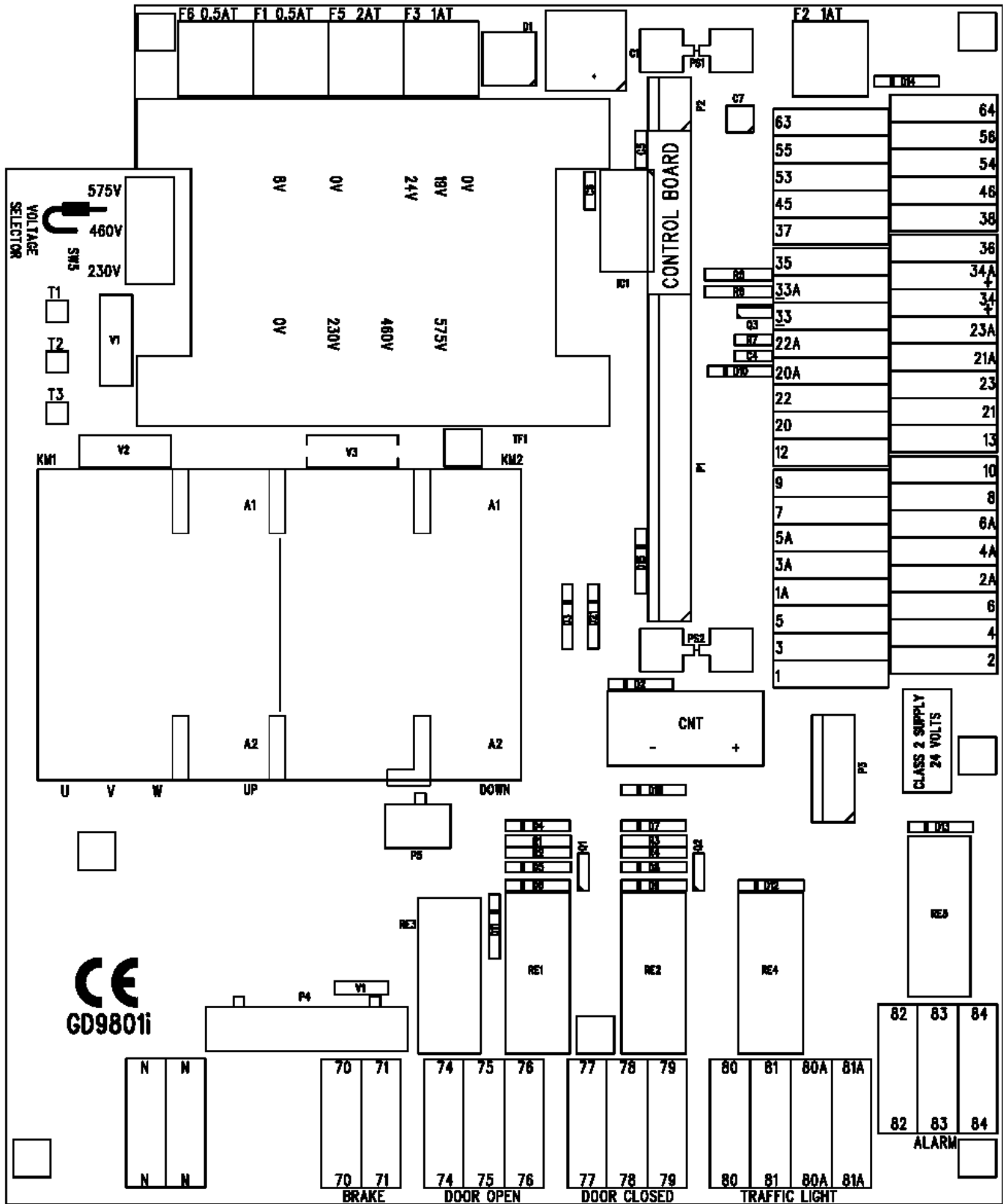

**FIGURE 7 – SINGLE SPEED MOTHERBOARD**

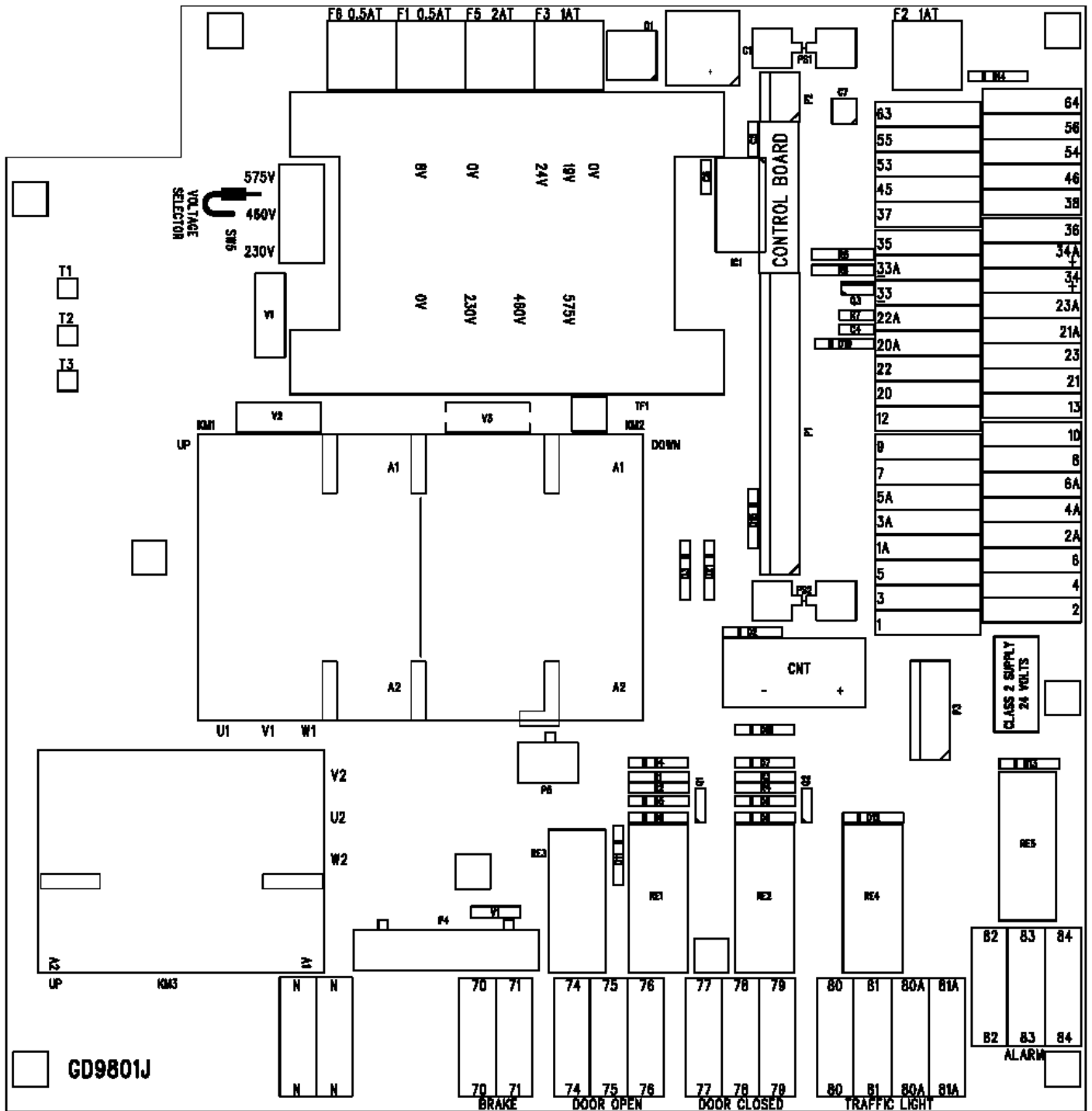

**FIGURE 8 – TWO SPEED MOTHERBOARD**

---

## Wiring to Panel

### Incoming Power

Three Phase power coming from a **FUSED DISCONNECT** is wired into T1, T2, and T3. Located on the disconnect.

### Voltage Selector (J2)

Check J2 for the proper incoming voltage level. This jumper wire comes from the motherboard and is terminated on a terminal below the control transformer. This is factory preset and should not normally need to be changed.

### Pneumatic safety edge (if equipped)

The pneumatic edge pressure switch is wired to a set of terminals **7A** and **8A** for rapid roll doors, which is mounted on the din rail right below the motherboard. (Required for door operation.)

### Electric Edge Connection (if equipped)

Connect the electric edge directly to terminals 7 and 8 (edge is not adjustable). To test, (turn power on) bump the rubber safety edge with your hand observe LED 6 (see Figure 5 for location), it should flash on briefly. The edge is now operational.

### Ground Bar

All grounds coming into the panel should be terminated on the ground bar at the bottom of the panel.

### Wiring Of The Motherboard

The motherboard component layout and numbering is shown in **Figure 7** for ONE-speed motors, and in **Figure 8** for TWO-speed motors. Also refer to wiring diagrams in this manual. **Table 1** shows the motherboard terminal listing and descriptions. For any additional external devices not covered in this manual consult the factory for wiring details.

**Table 1 - Mother Board Terminal Wiring**

Terminal	Notice	Description
T3, N, N	NOT USED	Mains output ( <b>NOT USED</b> )
U, V, W		Motor (Single Speed)
U2, V2, W2	2 speed motors	Motor (Two Speed)
1 & 2		Stop 1 - N.C.
1A & 2A	Inertia Brake if applicable	Stop 2 - N.C.
3 & 4		Open - N.O.
3A & 4A		Open - N.O.
5 & 6		Close - N.O.
5A & 6A		Close - N.O.
7 & 8		Electric Safety edge, resistor principle, 8,2kOhm
9 & 10		Limit switch "Door opened"
12 & 13		Limit switch "Door closed"
20	Primary safety photo See WD503-PC000 for details	Safety photocell 1 – power (DC-)
21		Safety photocell 1 - power (DC+) Switched for self test
22		Safety photocell 1 - power (DC+)
23		Safety photocell 1 - Signal
20A	Secondary safety photo See WD503-PC000 for details	Safety photocell 2 – power (DC-)
21A		Safety photocell 2 - power (DC+) Switched for self test
22A		Safety photocell 2 - power (DC+)
23A		Safety photocell 2 - Signal
33		Output, 24VDC Negative
33A		
34		
34A		Output, 24VDC Positive
35 & 36		Thermal switch contact N.C.
37 & 38		Hoist disengagement switch N.C.
45 & 46	Typically not used	Crash sensor (Jumper) N.C.
53 & 54		Reserve, input
55 & 56		Reserve, output
63 & 64		Output, 24V AC
70 & 71		BRAKE (180 VDC output) Requires rectifier in panel for output
74	Optional	Dry contact contact "Door opened" (Common) Dry contact contact "Door opened" (N.O.) Dry contact contact "Door opened" (N.C.)
75	Optional	
76	Optional	
77	Optional	Dry contact contact "Door closed" (Common) Dry contact contact "Door closed" (N.O.) Dry contact contact "Door closed" (N.C.)
78	Optional	
79	Optional	
80 & 81	Optional	Dry contact contact "Warning light"
80A & 81A	Optional	
82	Optional	Dry contact contact " Alarm, Door not ready " (N.O.)
83	Optional	Dry contact contact " Alarm, Door not ready " (Common)
84	Optional	Dry contact contact " Alarm, Door not ready " (N.C.)

N.O. = Normally open    N.C. = Normally closed

# ACS-50 Settings And Electrical Startup

## CPU Card Switch Settings

### (SW2) Rotary Selector Switch for Closing Time

Automatic closing can be set from 1-60 seconds. The potentiometer (SW2) is located on the CPU-card; see **Figure 12** and **Table 2** for settings.

**Note:** the SW2 in combination with the SW1 setting also has an effect on the operation sequence as shown in **Table 4**. Refer to **Figure 12** for switch location.

**TABLE 2 – SW2 Settings**

SW2 Position	0	1	2	3	4	5	6	7	8	9	A	B	C	D	E	F
Close Time	↓	1	2	3	4	5	7	10	13	16	19	22	25	30	45	60

**Note:** When SW2 is set in position 0, the door will not automatically close. You need to give a new impulse of an OPEN device to close the door or impulse a CLOSE device.

### Jumper J1- Bottom Edge Selector

The Jumper1 is located on the CPU-card as shown on **Figure 12**. This is factory set as shown below.

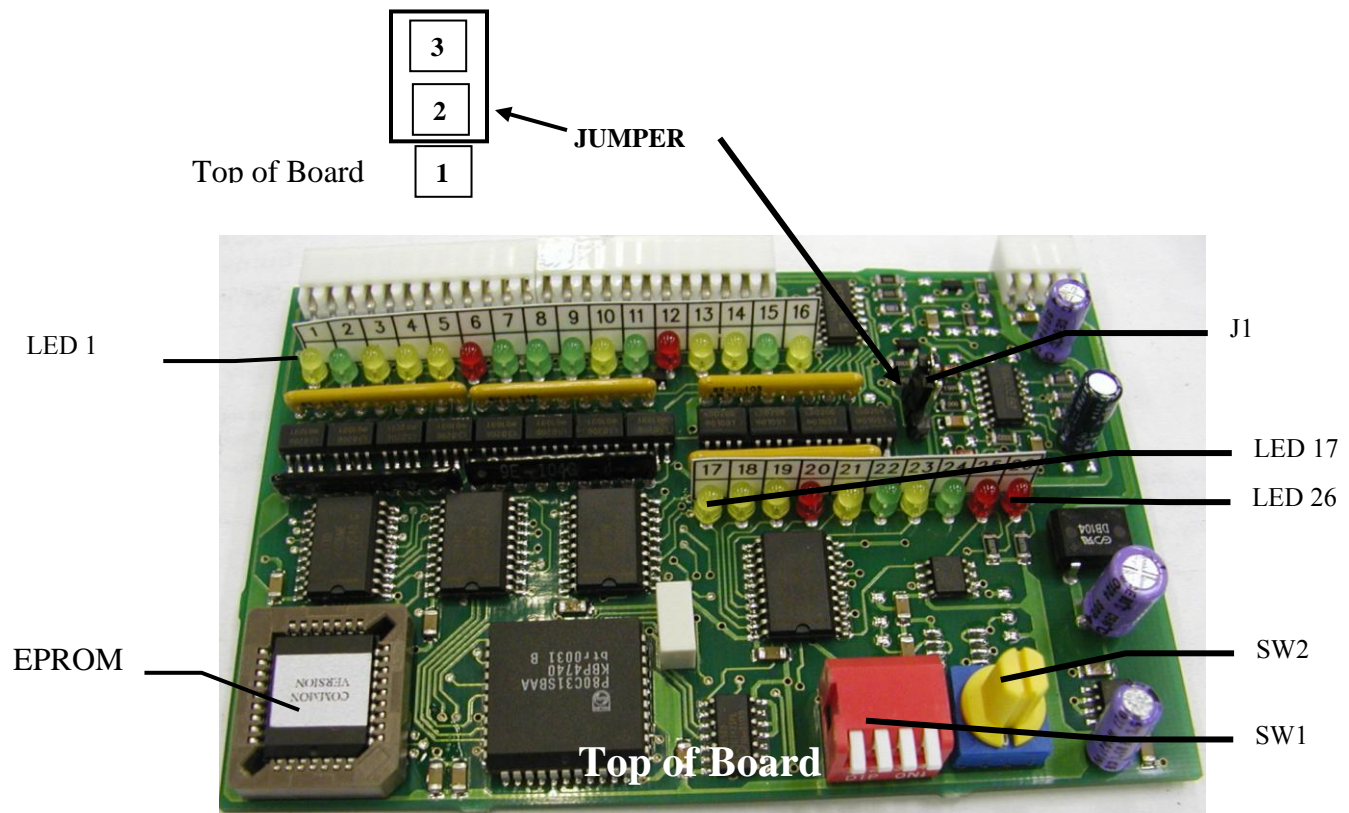

**FIGURE 12 – CPU Card**

## Setting of Opening and Closing Functions

In the table below, **SW1.1** means switch position 1 on **SW1** dipswitch. Likewise, **SW1.2** means switch position 2 on **SW1** dipswitch. Refer to **Figure 12** for switch location. The greyed out section below shows the factory settings. You need to change these settings for your particular needs.

**Table 3– Setting of Opening and Closing Functions**

SW 1.1	SW 1.2	SW 2	Terminal 3(A),4(A) (Remote Activation)	Terminal 5(A),6(A) (Remote Activation)	Panel Buttons	
					UP	DOWN
ON	ON	0	UP – DOWN	UP – DOWN	UP	DOWN
ON	ON	1-F	UP – AUTO. + CAP	UP – DOWN	UP- AUTO	DOWN
ON	OFF	0	UP	UP – DOWN	UP	DOWN
ON	OFF	1-F	UP – AUTO.	UP – DOWN	UP - AUTO	DOWN
OFF	ON	0	UP + CAP	DOWN	UP - CAP	DOWN
OFF	ON	1-F	UP – AUTO.	UP – AUTO.	UP - AUTO	DOWN
OFF	OFF	0	UP	DOWN	UP	DOWN
OFF	OFF	1-F	UP – AUTO.	DOWN	UP - AUTO	DOWN

### SW1.3

**OFF** = Does not require reset after safety edge trip.

**ON** = Requires reset after safety edge trip. Must reset by hold to close by pressing down button and fully closing the door

### LEGEND for Table 3:

**AUTO.** = Automatic closing from open position. Delay before close time is adjustable from 1 sec to 60 seconds depending on SW2 setting as specified in **TABLE 2**. The UP button (or 3(A) & 4(A) remote) will reset the timer, and prevent the door from closing until released. The shaded row in the above table is the most commonly used settings for auto close function.

**CAP** = Automatic “**CLOSE AFTER PASSING**” the door photocell. The door will remain open until the photocell beam is broken and re-established. If the door is in UP – AUTO + CAP mode, it will then close after a fixed 2-second delay (not adjustable) once the photos have been passed through and cleared. If the door is in UP –CAP mode, the door will then close after the UP (or 3(A) & 4(A) remote) or DOWN (or 5(A) & 6(A) remote) buttons are pressed.

**UP – DOWN** = When the door is open, an impulse of the UP button (or 3(A) & 4(A) remote) will close the door when in this mode.

**Table 4 – LED Indication of the CPU Card**

LED #	LED COLOR	Wiring Terminals / Notes	Function	Status Open	Status (MID)	Status Closed
1	Yellow	3(A) & 4(A) 5(A) & 6(A)	Signal Open	OFF	OFF	OFF
2	Green	1 & 2 or 1A & 2A <b>(Jump if not used)</b>	Signal Stop / Inertia Brake if applicable	ON	ON	ON
3	Yellow		Signal Close	OFF	OFF	OFF
4	Yellow	9 & 10	Limit switch "Door opened"	ON	OFF	OFF
5	Yellow	12 & 13	Limit switch "Door closed"	OFF	OFF	ON
6	Red	7a and 8a if pneumatic 7 and 8 if Electric (8.2KΩ resistor to bypass into 7 & 8)	Safety edge (on if activated)	OFF	OFF	OFF
7	Green	20,21,22,23 (Jump 21 to 23 to bypass for testing only) See schematics for color code wiring	Safety photocell 1 (off if beam is blocked or not aligned)	ON	ON	ON
8	Green	35 & 36 (Jump if not used)	Thermal contact	ON	ON	ON
9	Green	37 & 38 (Jump if not used)	Manual lever or Hoist disengagement	ON	ON	ON
10	Yellow	Ribbon cable	Open button of the control box	OFF	OFF	OFF
11	Green	45 & 46 (Jump if not used)	Crash sensor	ON	ON	ON
12	Red		Optional input	---	OFF	OFF
13	Yellow	On while door is closing	Test of "close"-relay	OFF	OFF	OFF
14	Yellow	Ribbon Cable	Close button of the control box	OFF	OFF	OFF
15	Green	20A, 21A, 22A, 23A (Jump 21A - 23A to bypass for testing only) See schematics for color code wiring	Safety photocell 2 (Off if beam is blocked or not aligned)	ON	ON	ON
16	Yellow		Not Used	OFF	OFF	OFF
17	Yellow	(Tab on open contactor will move when door is opening)	Relay "Open"	OFF	OFF	OFF
18	Yellow	(Tab on close contactor will move when door is closing)	Relay "Close"	OFF	OFF	OFF
19	Yellow	70 & 71 – (Measure 180 VDC output)	Brake	OFF	OFF	OFF
20	Red	Red illuminated stop button on the face of the control box	<b>(FLASHES FOR 3 SECONDS ON STARTUP)</b> <b>Solid if error. Verify LED's on this chart</b>	OFF	OFF	OFF
21	Yellow	80 & 81 / 80A & 81A 10A 250VAC DRY CONTACT ONLY	Traffic light or Warning light / horn (On during open & 2 sec's prior to & closing)	OFF	OFF	OFF
22	Green	82 & 83 N.O. / 83 & 84 N.C. 10A 250VAC DRY CONTACT ONLY	Alarm / Fault Indicator	ON	ON	ON
23	Yellow		Optional output		OFF	OFF
24	Green		Test of the photocell	ON	ON	ON
25	Red	Check photo wiring for bad connections	Error indicator – Photocell has a short circuit	OFF	OFF	OFF
26	Red	Dip switch SW 1.3 is set to on	Error indicator – Safety edge requires reset (see SW1.3)	OFF	OFF	OFF

The GFA limit assembly is shown below. Setting of these limits is required prior to running the door. See the following instruction for limit setting procedures. The limit assembly is located on the bottom side of the gearbox and in most applications behind the motor under a black plastic limit cover.

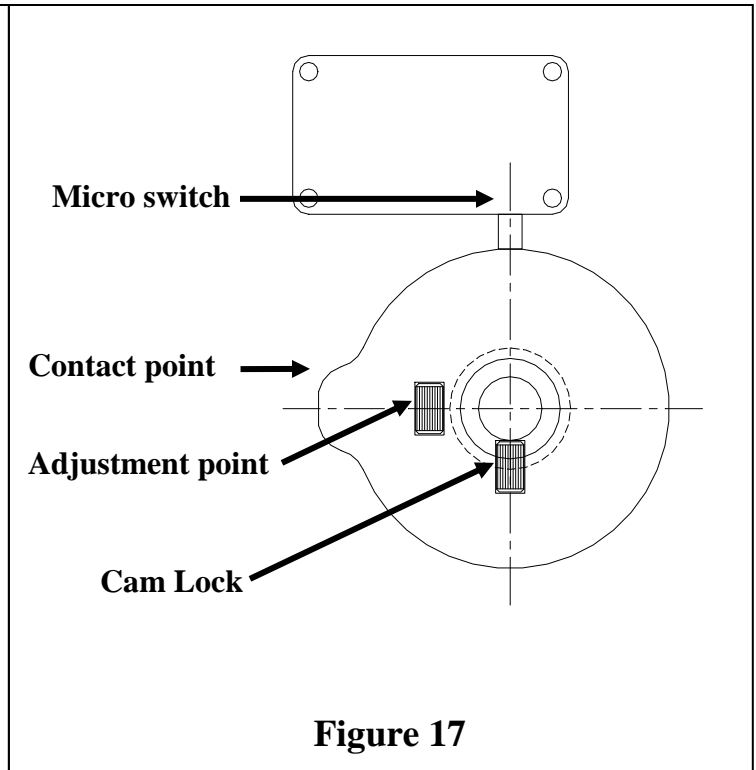
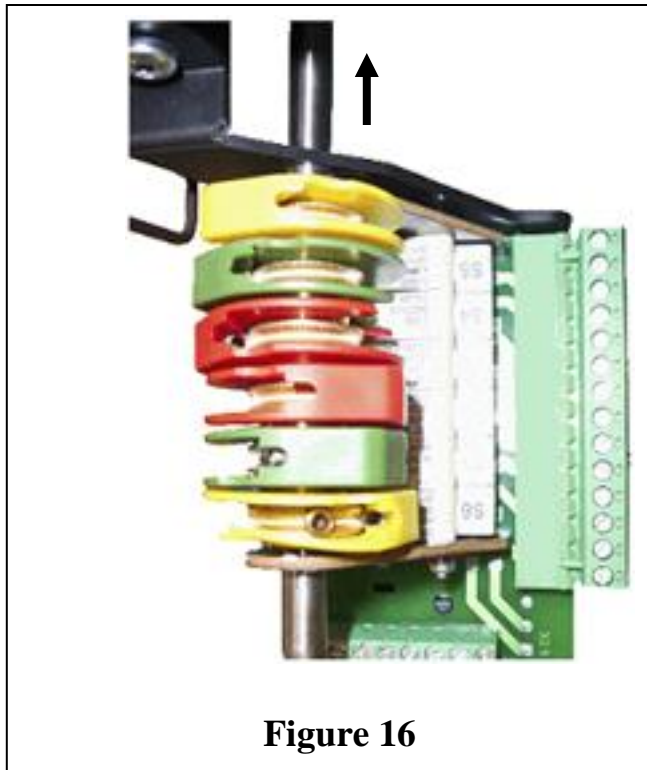

## Limit Switch Coarse Adjustment

Refer to the Operator Wiring schematics of this manual for limit wiring.

# Warning

Rotation of the open limit cam in the wrong direction or incorrect phasing may cause the bottom beam assembly to jam into the top roll.

1. Remove the limit switch box cover, and manually bring the door down 1' below the full open position. Observe the rotation direction of the limit cams while the door moves.
  - **NOTE: A SMALL CHANGE IN THE CAM POSITION WILL RESULT IN A LARGE CHANGE IN THE MOVEMENT OF THE DOOR.**
  - Using the included Allen wrench loosen and then rotate the open limit cam (figure 17 & 18) until it makes contact with its associated micro switch. Then lock the cam with the Allen wrench. The RED open and close safety limit cams are pre-adjusted and are piggybacked to the Green open and close limit cams. If this safety point needs to be corrected this can be adjusted using the fine adjustment screw to advance or retard the position of the red cam in relation to the position of the green cam. The red cams are so the door stops safely if the direction of the rotation is reversed or the open limit switch fails. During normal operation the RED cams should never make contact with their switch but should be close enough to activate if the primary limits fail.
2. Rotate the open limit cam until it makes contact with its associated micro switch.
3. If the door is equipped with the standard photocells (not light curtains) the lower S6 Yellow cam must be set at this point to filter the photos to prevent the bottom edge from reversing the door open. Doors equipped with light curtains do not require this photo bypass limit and it must be set so that it never makes contact with its switch.
4. Move the door to one foot from the fully closed position. Observe the rotation direction of the limit cams while the door moves.
5. Rotate the closed limit cam until it makes contact with its associated micro switch.

## Turning on the Door Controller

When the door controller has been wired correctly, the switch **SW1** and **SW2** settings are complete, and the coarse limit adjustment is complete, the power may be turned on. Upon power up, the door controller will do an initial test for 3 seconds to see whether the software and the RAM are working properly. During this 3-second test, the controller will not respond to any open or close signals and the door will not open or close and the red illuminated button on the control box will flash.

If the test detects a failure, the red illuminated button will illuminate constantly, the alarm relay will be activated, and the door controller becomes locked.

When the initial-test is over and no fault has been detected, the controller is ready to work.

## Phase Check

**Note:** in this step it is assumed that the door is still closed from the coarse limit-setting step.

1. Be prepared to press the STOP button. **(Stop on the front panel is a momentary stop only! Door can be activated by motion detector, floor loop, or any activation device) It is highly recommended that ALL automatic or remote activations be disconnected during the**

**startup of the door. This will eliminate unwanted activations which can create startup issues.**

2. Push the open impulse button. The door should open at full speed.
  - 2.1. If the door starts to close, stop the door immediately by pressing the STOP button and swap the position of the incoming power wires to **T1 & T2**.
  - 2.2. If the door opens, make sure it stops at the open limit. If it goes beyond the open limit as set in the coarse limit-setting step, stop the door immediately and troubleshoot the limit wiring and/or setting.
3. Repeat this check until the door opens to top limit and stops at the close limit.

### **Hold-to-Run-Function**

If the safety edge or safety photocells (safety circuits) have any fault(s), the door will no longer close automatically, and the system will go into Hold-to-run mode. An illuminated Stop button on the control panel indicates hold-to-run mode.

If the Hold-to-run-mode is activated, it is not possible to close the door via external activators or signals. Only the control panel buttons will respond to a constant pressure to run the door.

It is necessary to push the “Close” button to reset the door controller. Every other signal to reset will not have any effect.

Reset of the Hold-to-run mode will occur when both safety circuits are working again and pushing the CLOSE button on the control panel successfully closes the door.

### **Input Device Check**

Press the **STOP** button to prevent the door from moving. Operate each applicable input device as listed in **Table 4** to verify device wiring. Refer to **Table 5** to understand the proper light indication. When finished, restore the door from hold to run mode as described above.

### **Runtime Monitoring**

The controller has an internal timer to measure the door run time when opening or closing. The timer expires after the door runs continuously for 40 seconds. If this occurs, the door will immediately stop and the red button on the panel will be lit solid. To reset this condition, disconnect main power (off). Verify that the door is not binding or you have a motor/gearbox problem. After this check, then reapply power.

### **Limit Switch Fine Adjustment**

Refer to the limit switch appendix for details on the specific limit switch type used on your door.

1. Make sure the door can be actuated to open and close properly and that the door stops at the coarse limit settings.
2. Make small adjustments to the cams and cycle the door open and closed to observe changes in the limit settings.
3. Continue to finely adjust each cam until the desired door limits are attained. Once the door limits are adjusted correctly and the door is operating satisfactorily. Replace the limit switch box cover. Ensure the limit cams are tightened and locked.

**Safety Circuit Limit Box (GFA Drives Only)**

The terminals 21 to 28 on the limit switch figure 18 are reserved for the safety circuit. An interruption of the safety circuit causes the control voltage to be interrupted. Electrical operation is no longer possible when this occurs.

**Photocell Cut-off (GFA Drives Only)**

The limit switch (S6) must be adjusted to bypass the photocells when the door is approximately 8 inches off the ground. This allows the bottom loop on the bottom beam assembly to clear the photocell and not cause the door to reverse. Not used with light curtains.

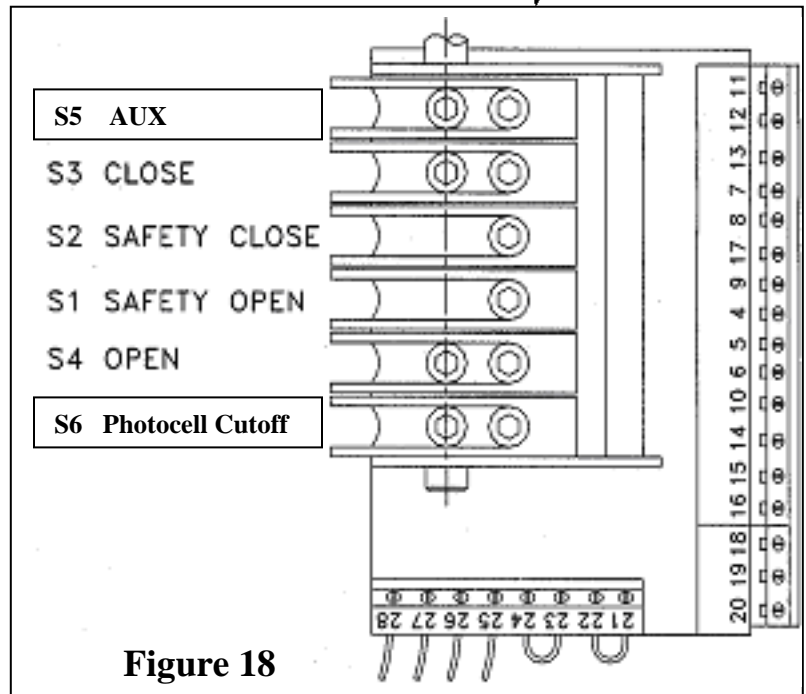

**Figure 18**

**Inertia Brake Wiring (if Equipped)**

(Chain drive doors without counter balance springs only)

The inertia brake needs to be wired in order for the door to operate. Refer to electrical drawings for wiring points. If the red indicator is extended from the housing of the inertia brake the electrical contact will be in an open position and thus preventing the door from operating. If the brake is activated it is a one time use brake and must be replaced.

**Wiring Schematics:**

Refer to the following pages for the applicable door schematics.

## WD501-GF002 – ACS50 GFA Operator Wiring 2-Speed

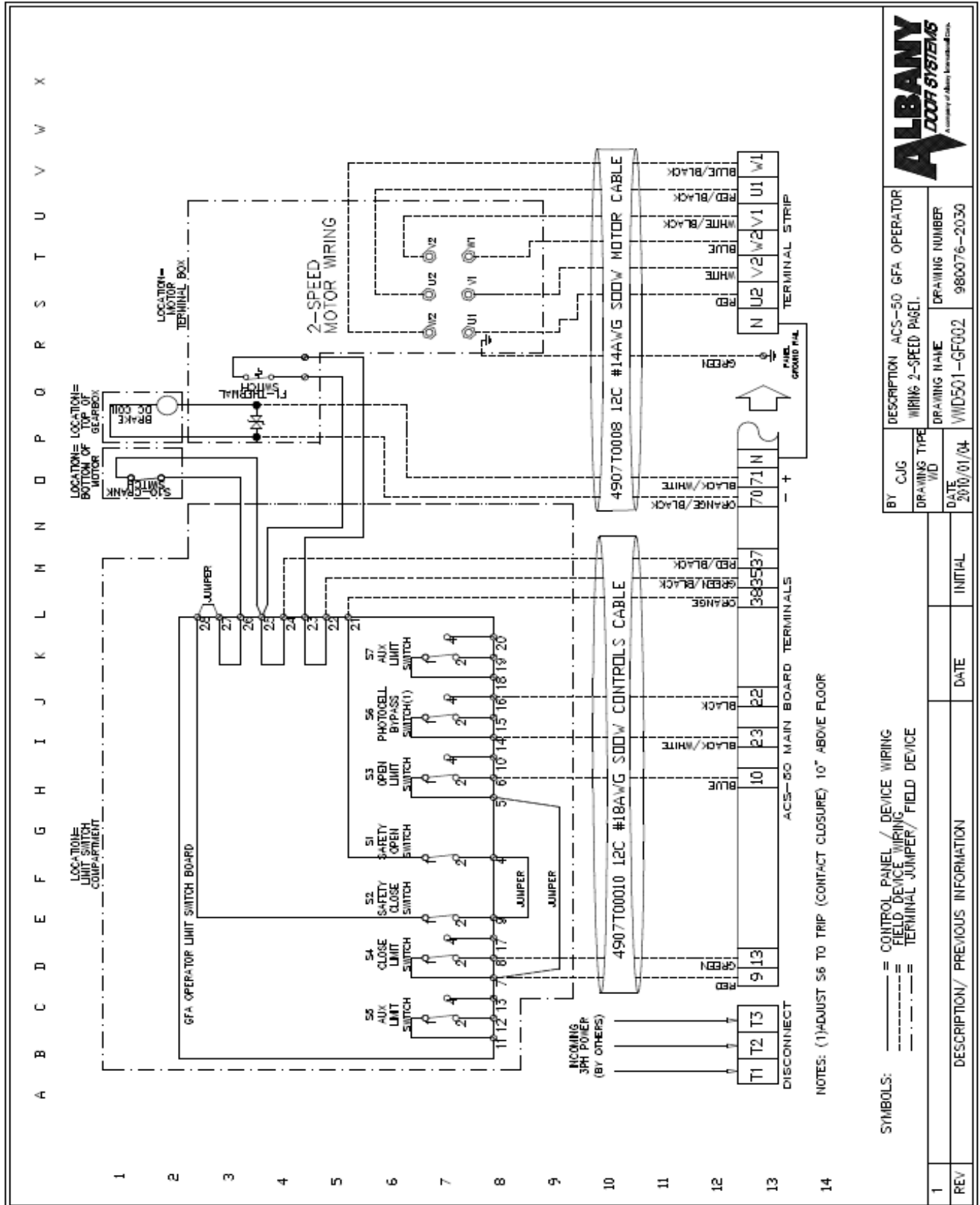

## WD501-GF001 - ACS50 GFA Operator Wiring 1-Speed

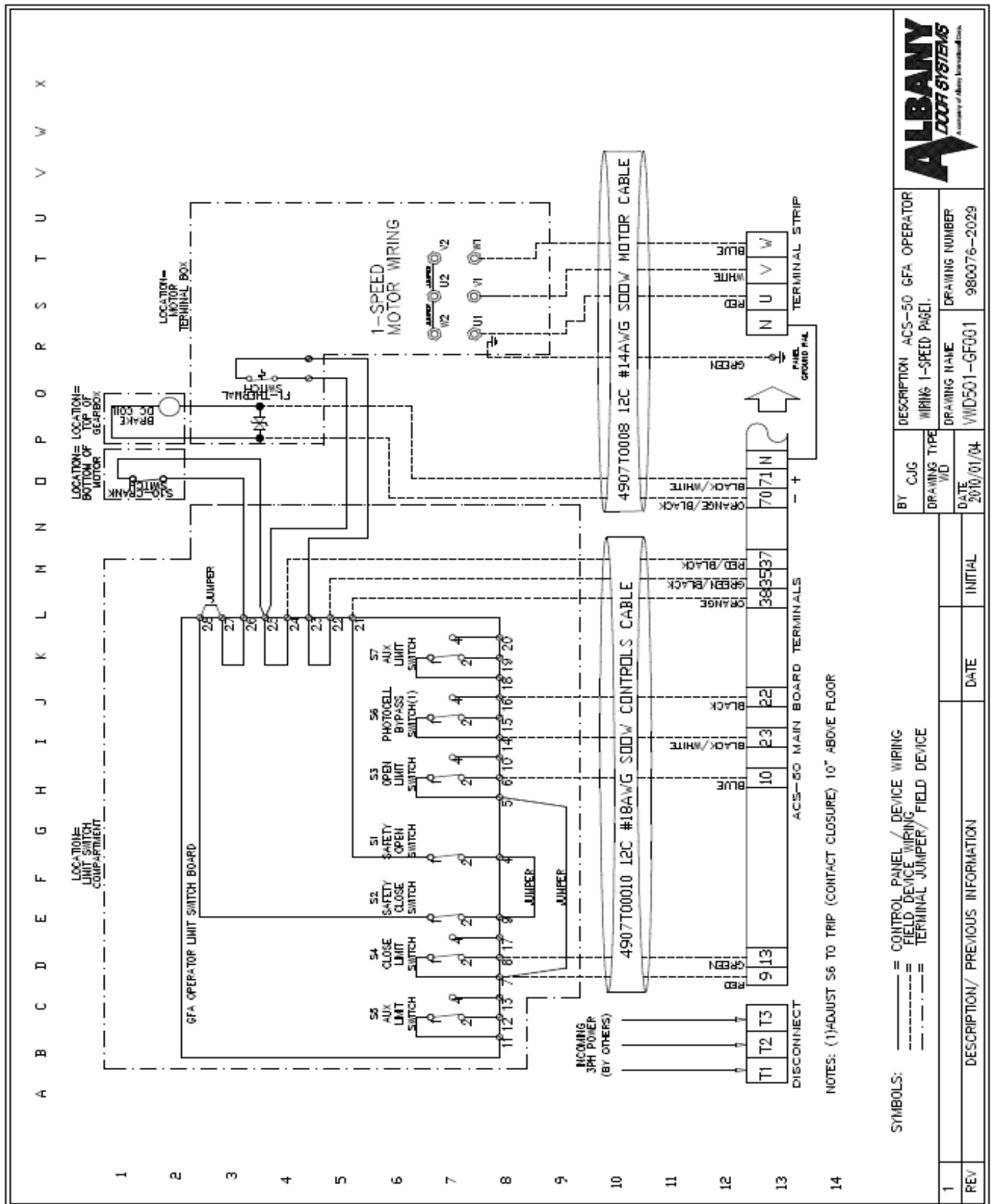

<b>BY</b> CUG	DESCRIPTION ACS-50 GFA OPERATOR WIRING 1-SPEED PAGES.	DRAWING NAME	DRAWING NUMBER
<b>DATE</b> 2010/01/04		WD501-GF001	980076-2029

## WD502-0000-1 = Door Control Wiring and Electric Edge

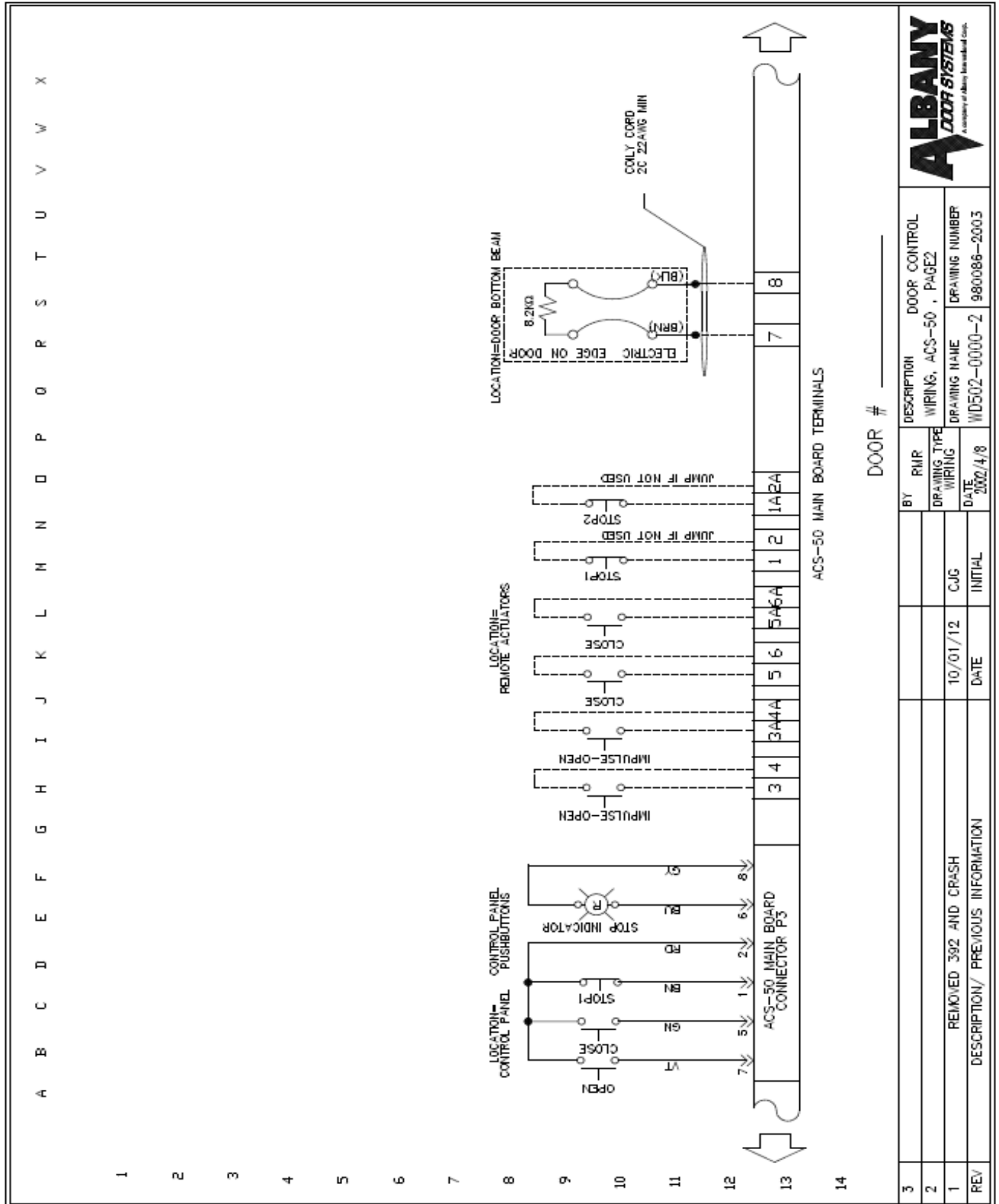

## WD503-PC000 = Reversing Photocell Wiring

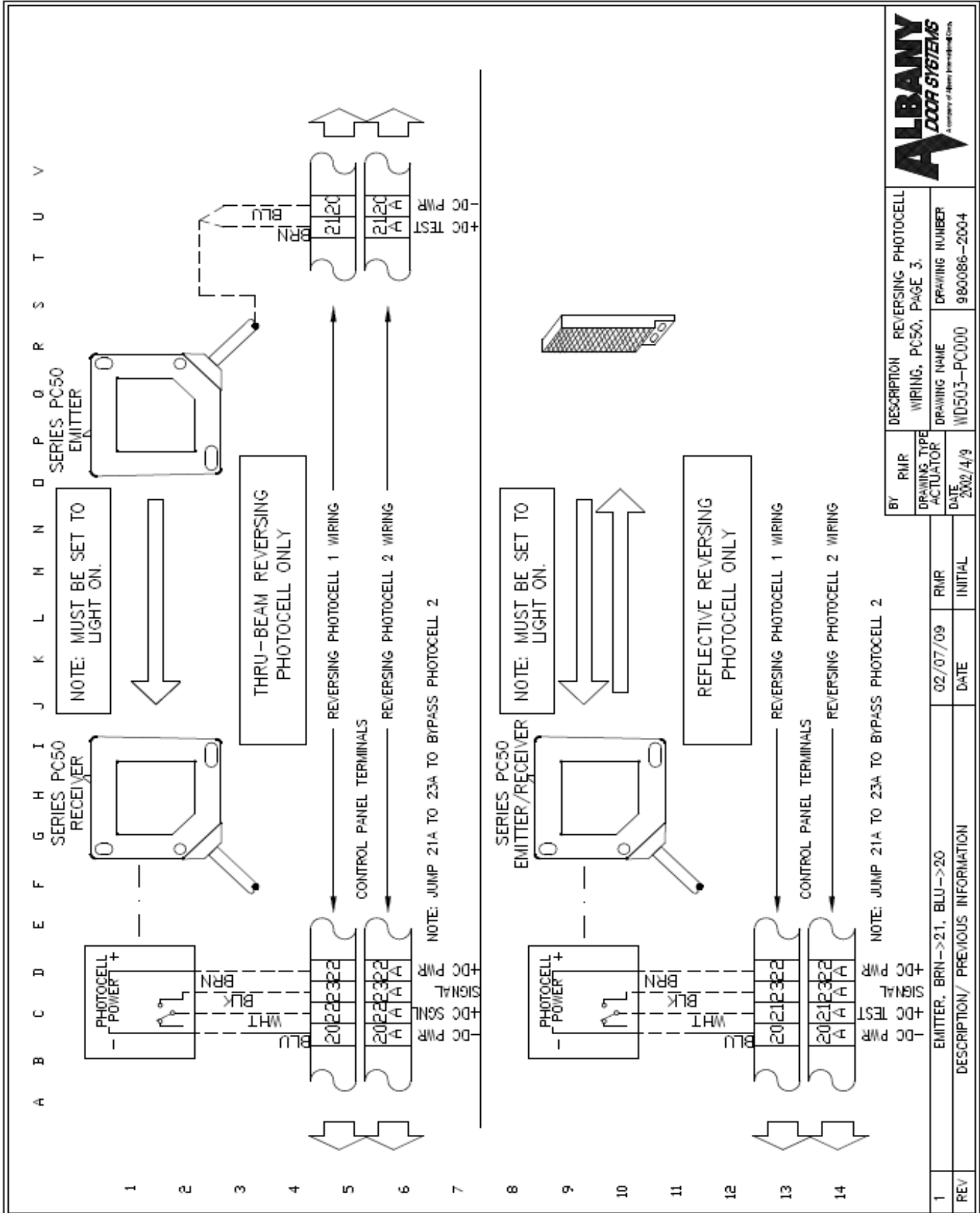

### LCASC50 = Blanking Light Curtain Photocell Wiring

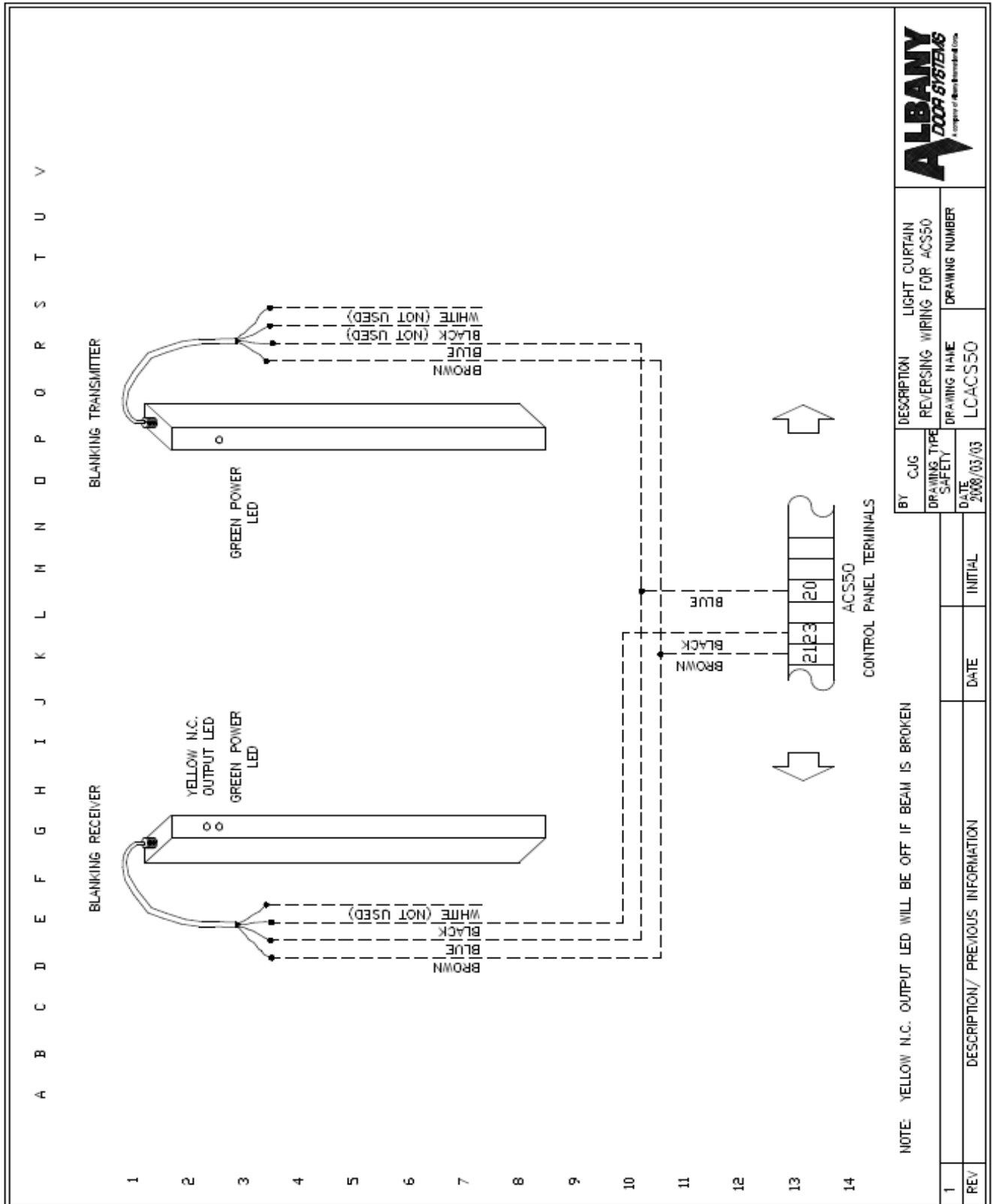

BY CUG		DESCRIPTION	LIGHT CURTAIN REVERSING WIRING FOR ACS50	
DRAWING TYPE SAFETY		DRAWING NAME	LCASC50	
DATE 2/08/03/03		DRAWING NUMBER		
1	REV	DESCRIPTION/ PREVIOUS INFORMATION	DATE	INITIAL

## WD504-0000 = ACS50 Actuator Options

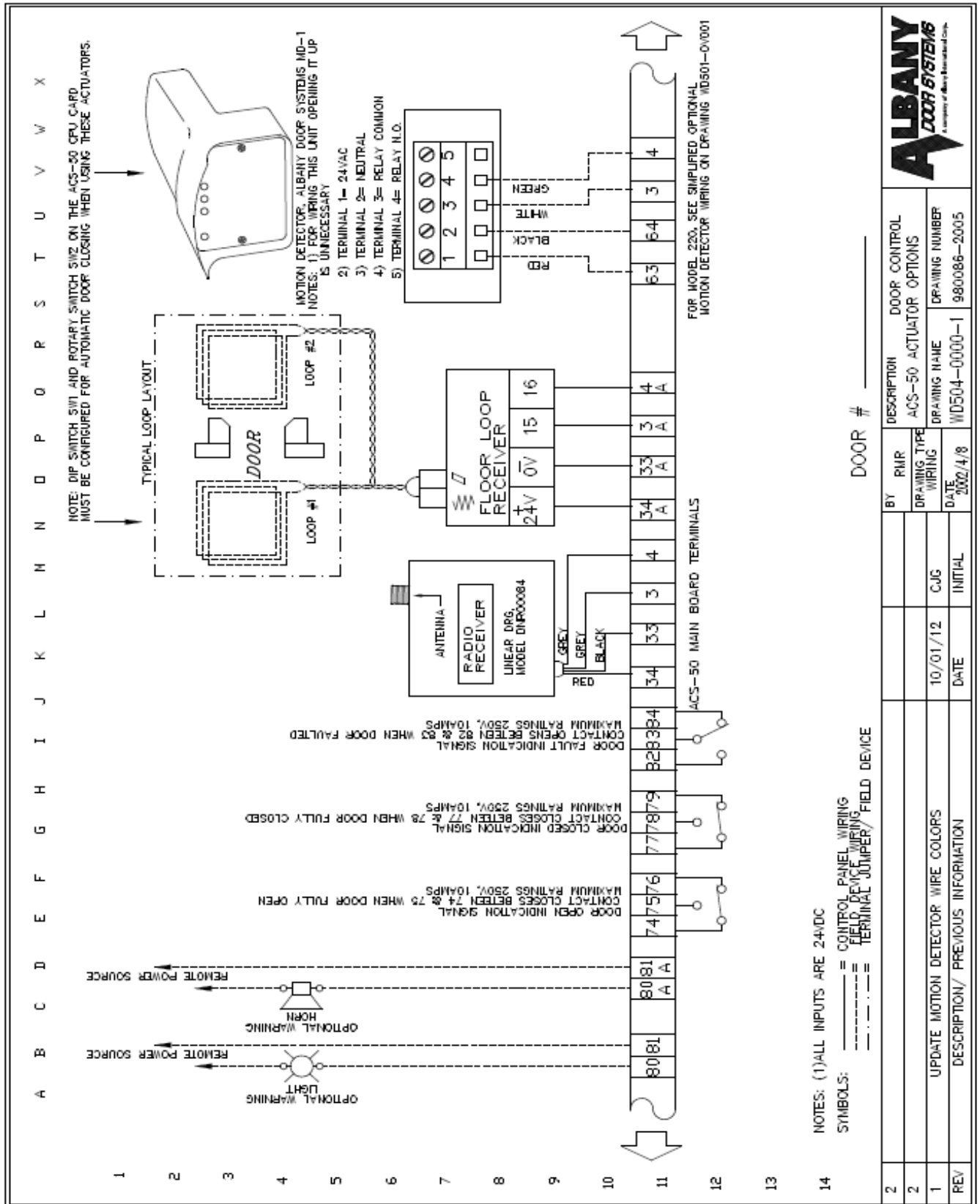

**WD502-0000A = Interlocking two ACS50 Units**

A B C D E F G H I J K L M N O P Q R S T U V W X

1

2

3

4

5

6

7

8

9

10

11

12

13

14

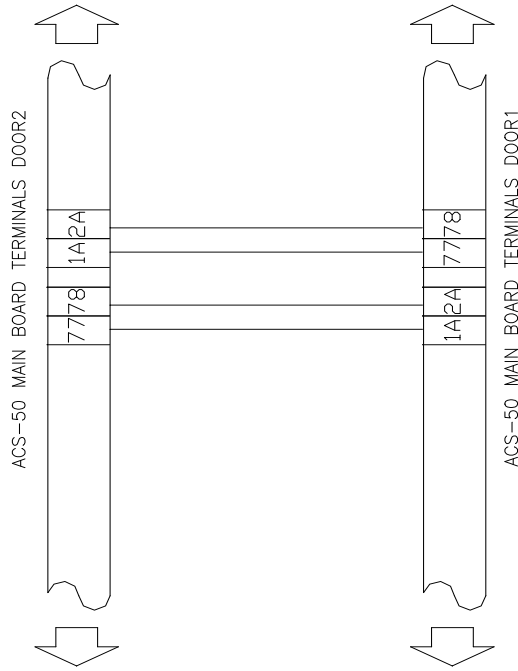

NOTES: (1) NO OTHER DEVICES CAN BE CONNECTED TO 1A, 2A, 77, OR 78 IN EITHER DOOR FOR THIS WIRING TO FUNCTION  
 (2) JUMPERS MUST BE REMOVED FROM 1A TO 2A IN EITHER DOOR FOR THIS WIRING TO FUNCTION

SYMBOLS: \_\_\_\_\_ = CONTROL PANEL WIRING  
 \_\_\_\_\_ = FIELD DEVICE WIRING  
 - - - - - = TERMINAL JUMPER / FIELD DEVICE

REV	DESCRIPTION / PREVIOUS INFORMATION	DATE	INITIAL
		2003/4/11	
BY	RMR	DESCRIPTION	INTERLOCK CONTROL WIRING, ACS-50 TO ACS-50
DRAWING TYPE	WIRING	DRAWING NAME	WD502-0000A
DATE	2003/4/11	DRAWING NUMBER	



## Troubleshooting

**Table 5- Controller Faults**

Red Lamp + LED 20 (ON PANEL STOP BUTTON)	Alarm (OUTPUT TERMS 82-84)	Error Description	Indication
Flash	ON	Power on test	First 3 seconds after Power on
Flash	ON	Manual lever, Hoist, activated	LED 9 = OFF
ON	ON	Safety edge error	LED 6 = ON
ON	ON	Photocell error	LED 25 = ON
OFF	OFF	Photocell blocked	LED 7 = OFF (Photocell 1) LED 15 = OFF (Photocell 2)
ON	ON	Thermal contact activated	LED 8 = OFF; Door controller is locked
ON	ON	Safety edge was triggered: SW1-3 = ON	LED 26 = ON
ON	ON	EPROM Check sum error	Door controller is locked; No "power on test" indication
ON	ON	RAM Error	Door controller is locked; No "power on test" indication
<p>If LED's 7, 8, 9, or 15 is not on when the system is powered up it will go into a locked condition. Reset power and see which light is not lit and then check that item to get that light to be on.</p>			
<p>If you have all the proper LED except for LED's 2 &amp; 4 you need to check the wiring and or jumpers at terminals 1&amp; 2 or 1A &amp; 2A.</p>			
<b>No lights on the CPU CARD</b>		<p>Terminal 33 and 34 should have 24VDC available if not check fuses. Also check terminal 63 and 64 for 24VAC</p>	

## Control Panel Replacement Parts

PART #	PART DESCRIPTION
4903T0001	Control Panel, ACS50, 220/480/600v, 1-Speed CUL
4903T0002	Control Panel, ACS50, 220/480/600V, 2-Speed CUL
4903T0003	Control Panel, ACS50, Stainless Steel 220/480/600V, 1-Speed
4903T0004	Control Panel, ACS50, Stainless Steel 220/480/600V, 2-Speed
4906T0016	ACS50 Steel Enclosure With Prepunched Holes
4908T0011	Fuse Holder, ACS50
4909T0001	Rectifier, ACS50, 220 Volt, CUL
4911T0012	Terminal Block, 6mm, 35mm Din Rail
4911T0013	Terminal Block, End Stop, 35mm Din Rail
4920T0001	Motherboard, ACS50, CUL, One Speed (Does not include CPU card or rectifier)
4920T0002	Motherboard, ACS50, CUL, Two Speed (Does not include CPU card or rectifier)
4920T0009	CPU CARD, ACS50 w/ 4916T0002 40 Sec Run Time Eprom
980072-4019	Resistor, 8.2K, 1/8w Pigtail for Pnuematic edge
980072-7504	Disconnect, Rotary Switch, Rod And Handle Included
980072-9500	FUSE, ACS50, 250V1A, F2 & F3 position
980072-9501	FUSE, ACS50, 250V 0.5A F1 & F6 position
980082-7505	Push Button, Red, ACS50
980082-7506	Push Button, Amber, Open/Close, ACS50
4904.415	Loop Detector, 24 VDC/AC, FEIG

### **Albany Door Systems Customer Service**

#### Aftermarket Parts

770-338-5000 Tel

770-338-5034 Fax

[service@albanydoors.com](mailto:service@albanydoors.com)

#### Technical Support

262-268-9885

[service@albanydoors.com](mailto:service@albanydoors.com)

**NOTES:**

<b>DOCUMENT TITLE</b>	<b>ACS-50 Control Panel for UltraTough</b>		
<b>DOCUMENT NUMBER</b>	<b>6410T0013</b>	<b>ISSUE DATE</b>	<b>January 2010</b>
<b>DOOR MODEL(S)</b>	<b>UltraTough</b>	<b>ELECTRONIC FILE</b>	<b>ACS50-UltraTough 6410T0013.doc</b>
<b>ASSEMBLY</b>	<b>Controls</b>	<b>REPLACES</b>	