

## UltraSecure 3000 Mechanical Installation

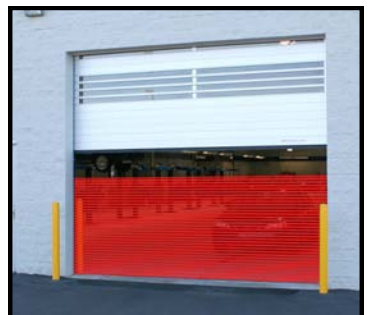

## STATEMENT OF WARRANTY

### UltraSecure 3000 High Speed Doors ONE-YEAR WARRANTY ON MECHANICAL AND ELECTRICAL COMPONENTS

- **Albany Door Systems** warrants to the original owner of the door that the mechanical and electrical components will be free from defects in material and workmanship for a period of **one (1) year** from the date of shipment. The warranty does not cover fuses, heat lamp elements, bulbs, and seals.
- Only defects brought to the attention of **Albany Door Systems** during the warranty period will be covered by this warranty.
- **Albany Door Systems** will replace component parts covered by this warranty, which are found to be defective upon inspection by an **Albany Door Systems** representative. Installation or use of parts other than those authorized by **Albany Door Systems** will void this warranty.
- PARTS AND ASSEMBLIES sold separately by **Albany Door Systems** that fail due to defects in material or workmanship within **ninety (90) days** from the date of shipment will be replaced under warranty provided installation has been carried out in accordance with all **Albany Door Systems** procedures. This warranty is limited to providing a replacement part only. This warranty does not cover freight, special charges, or any costs associated with the installation of the replacement part.
- This warranty covers material failure under normal wear conditions; it does not cover damage caused by collision or other abuse of the product. Adjustments made to the control panel or to the mechanical operation of the door without the authorization of **Albany Door Systems** will void this warranty. Any changes made to product configuration without the express written approval from Albany Door Systems may null and void this warranty.
- **5` V U b m ` 8 c c f** Obligations Under This Warranty are limited to repairing or replacing the defective part including labor and **Albany Door Systems** shall not be responsible for any other losses or damages due to the operation of any door or parts covered by this warranty. Warranty parts will be shipped regular ground freight at the expense of Albany Door Systems.
- This warranty shall be void in its entirety if the failure of any product shall be caused by any installation, operation, or maintenance of the product which does not conform with the requirements set forth by the seller in the applicable product manuals or is in the result of any cause other than a defect in the material or workmanship of the product.
- No other oral or written representations made by **Albany Door Systems** or its agents are a part of this warranty unless specifically set forth in writing by an authorized **Albany Door Systems** official.

**THE ABOVE SET FORTH WARRANTY IS SELLER'S SOLE WARRANTY. SELLER MAKES NO OTHER WARRANTY OF ANY KIND WHATSOEVER, EXPRESSED OR IMPLIED; AND ALL IMPLIED WARRANTIES OF MERCHANTABILITY AND FITNESS FOR A PARTICULAR PURPOSE WHICH EXCEED THE AFORESTATED OBLIGATION ARE HEREBY DISCLAIMED BY SELLER AND EXCLUDED FROM THIS AGREEMENT.**

#### WARNING

**Do not install, operate or service the product unless you have read and understand the safety practices, warnings, installation and maintenance instructions contained in this manual.**

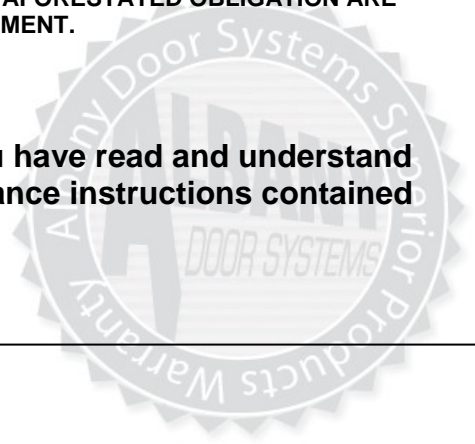

# INTRODUCTION

The contents of this manual are designed to help you install UltraSecure 3000 high speed doors. **DO NOT begin to install the high speed door unless you have read through the instructions in this manual.**

The safety alert symbol is used to identify safety information about hazards that can result in personal injury. A signal word (DANGER, WARNING, or CAUTION) is used with the safety alert symbol to indicate the likelihood and the potential severity of injury. In addition, a hazard symbol may be used to represent the type of hazard.

**DANGER** indicates a hazard that, if not avoided, will result in death or serious injury.

**WARNING** indicates a hazard that, if not avoided, could result in death or serious injury.

**CAUTION** indicates a hazard that, if not avoided, might result in minor or moderate injury.

**CAUTION**, when used without the alert symbol, indicates a situation that could result in damage to the door.

**NOTICE** is used to inform you of a method, reference, or procedure that could assist with specific operations or procedures.

Other symbols that may be used in this manual are:

**Lock Out / Tag Out**

**Crushing**

**Fire**

**Shock**

**Read Manual**

# Delivery and Inspection

Improper installation of anchoring devices or installation into aged or unsound concrete block, or other wall material may result in premature wear, product failure, property damage, or serious personal injury.

Lock-Out Tag-out all electrical power supplied to the door before making any electrical installations or connections. Also Lock-out Tag-out any equipment near the installation site if that equipment may be inadvertently operated into the area used to assemble and install the door. Failure to properly deenergize electrical circuits and disable equipment during installation and/or maintenance could result in death or serious injury.

Use proper lifting equipment and techniques. Properly secure all loads. Failure to properly secure all lifting loads could result in death or serious injury.

**Secure the work area so that persons not working directly on the installation do not enter the work area.**

## SITE PREPARATION

### Electrical Supply

Qualified electrician must make all electrical mountings and connections in accordance with all applicable regulating body(s) electrical codes and standards. See applicable electrical manual for specifications and wiring instructions..

### Door Opening

1. Are the door jambs and support wall structurally sound providing a flat surface for the side columns to mount against?
2. Check the width and height of the door opening and verify the measurements against the dimensions of the door.
3. Is the opening square? Plumb?
4. Is the floor level across the opening?

Make all necessary structural repairs and improvements

c [ Á ] | [ ç ã á ^ Á æ Á % ^ ^ • + Á æ } • , ^ | Á c [ Á æ & @ Á [ ~ Á c @ ^ Á ~ ^ • c ã [ ] • Á æ à [ ç ^ È

## TOOLS AND MATERIALS REQUIRED

### Personnel

- Two people to install the door
- One person qualified to operate forklift, hoist, or crane
- One electrician to install and connect the control panel and all electrical wiring

### Tools

- Assorted wrenches
- Tape measure
- Ô æ | ] ^ } c ^ | q • Á • ~ ~ æ | ^
- Level (4ft minimum recommended)
- Lifting device (fork lift, hoist, crane)
- Lifting Straps
- 2 ladders or personnel lifts (tall enough to reach above the door head)
- Other tools as needed for the type of anchoring chosen

### Materials

- Anchors appropriate for the type of wall the door and accessories are to be installed onto. Albany Door Systems recommends through-bolting doors whenever possible.
- Wire as specified on the electrical schematic
- Electrical supplies needed to comply with all regulating body electrical codes and standards.
- See applicable control manual with door.

## UNPACKING AND PREPARING

1. Inspect and unpack the components. Report any damage immediately to Albany Door Systems at 262-268-9885. Refer to the serial number tag located on the door side frame.
2. DO NOT cut the banding which holds the door in a roll until instructed to do so in a later procedure.

**The door panel and roll assembly could be damaged. Use evenly spaced padded supports to prevent rips, tears, or bending of the roll assembly. Failure to protect the roll assembly could result in damage to the**

## WALL ANCHORING GUIDE

Albany Door Systems does not supply hardware for mounting the door to the wall. Use proper hardware best suited for each particular door installation. Some examples are shown below. It is the responsibility of the door owner to ensure that the wall material is strong enough to support the forces of the door and all anchoring hardware. In general, Albany Door Systems recommends through-bolts, concrete anchors, or 1/2 inch diameter concrete expansion anchors.

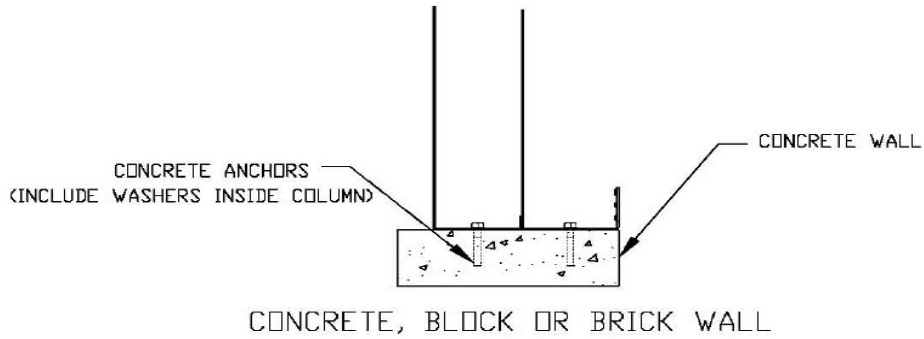
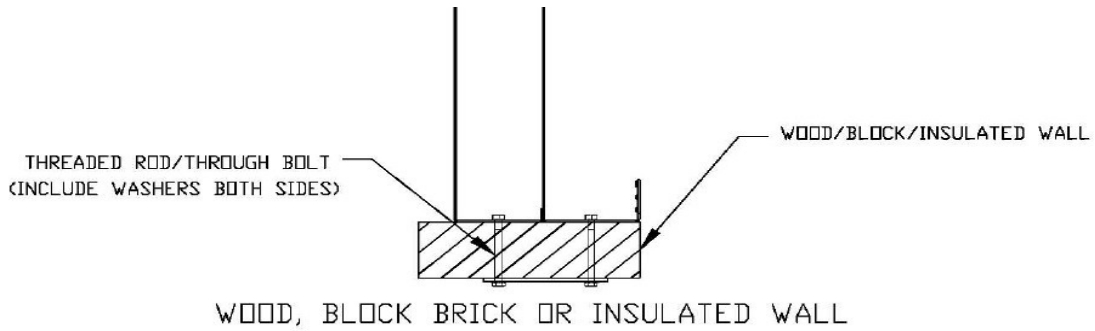

## INSTALLATION REFERENCE MARKS E3000R

Measure from the inside of the left door jamb to the inside of the right door jamb and place a mark on the floor on the door opening centerline.

Ü ^ ~ ^ | ^ } & ^ Á c @ ^ Á å [ [ | q • Á å [ & ~ { ^ } c æ c Door Width } å Á ] | æ & ^ Á  
2

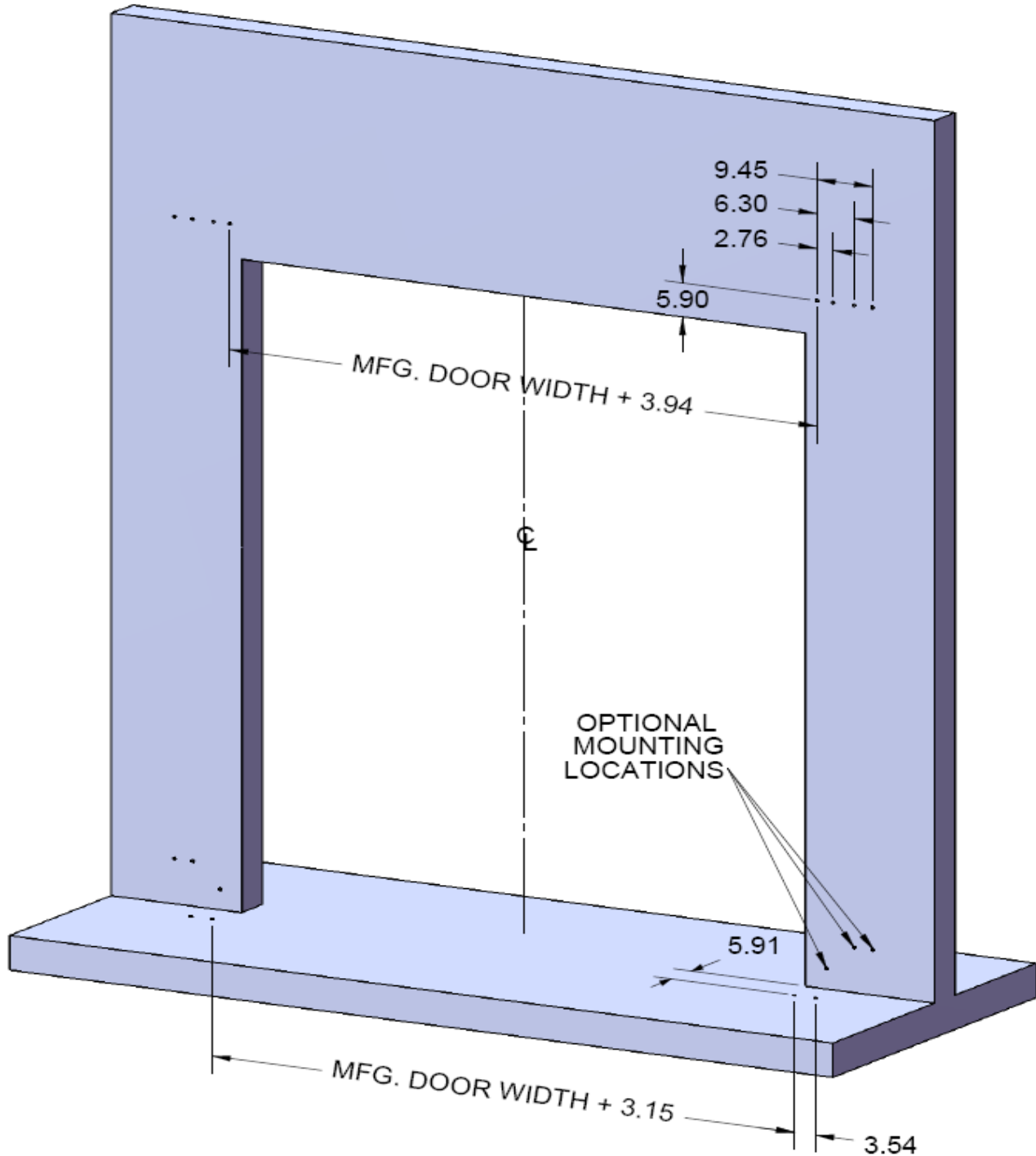

## INSTALLATION REFERENCE MARKS E3000STD

Measure from the inside of the left door jamb to the inside of the right door jamb and place a mark on the floor on the door opening centerline.

Ü ^ ~ ^ | ^ } & ^ Á c @ ^ Á á [ [ | q • Á á [ & ~ { ^ } c æ c Door Width á Á ] | æ & ^ Á  
2

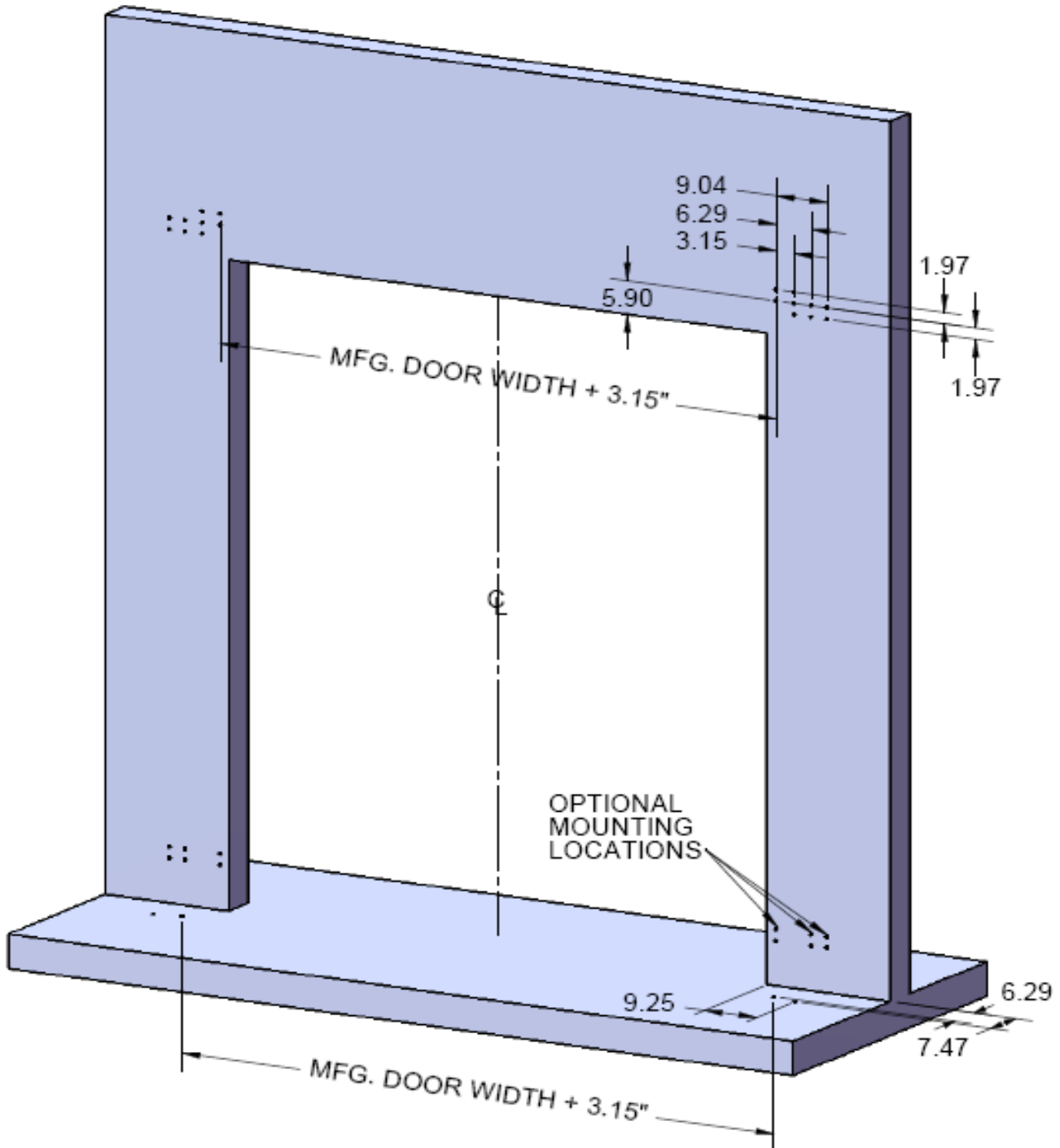

## INSTALLATION REFERENCE MARKS E3000XL

Measure from the inside of the left door jamb to the inside of the right door jamb and place a mark on the floor on the door opening centerline.

Ü ^ ~ ^ | ^ } & ^ Á c @ ^ Á á [ [ | q • Á á [ & ~ { ^ } c æ c Door Width } á Á ] | æ & ^ Á  
2

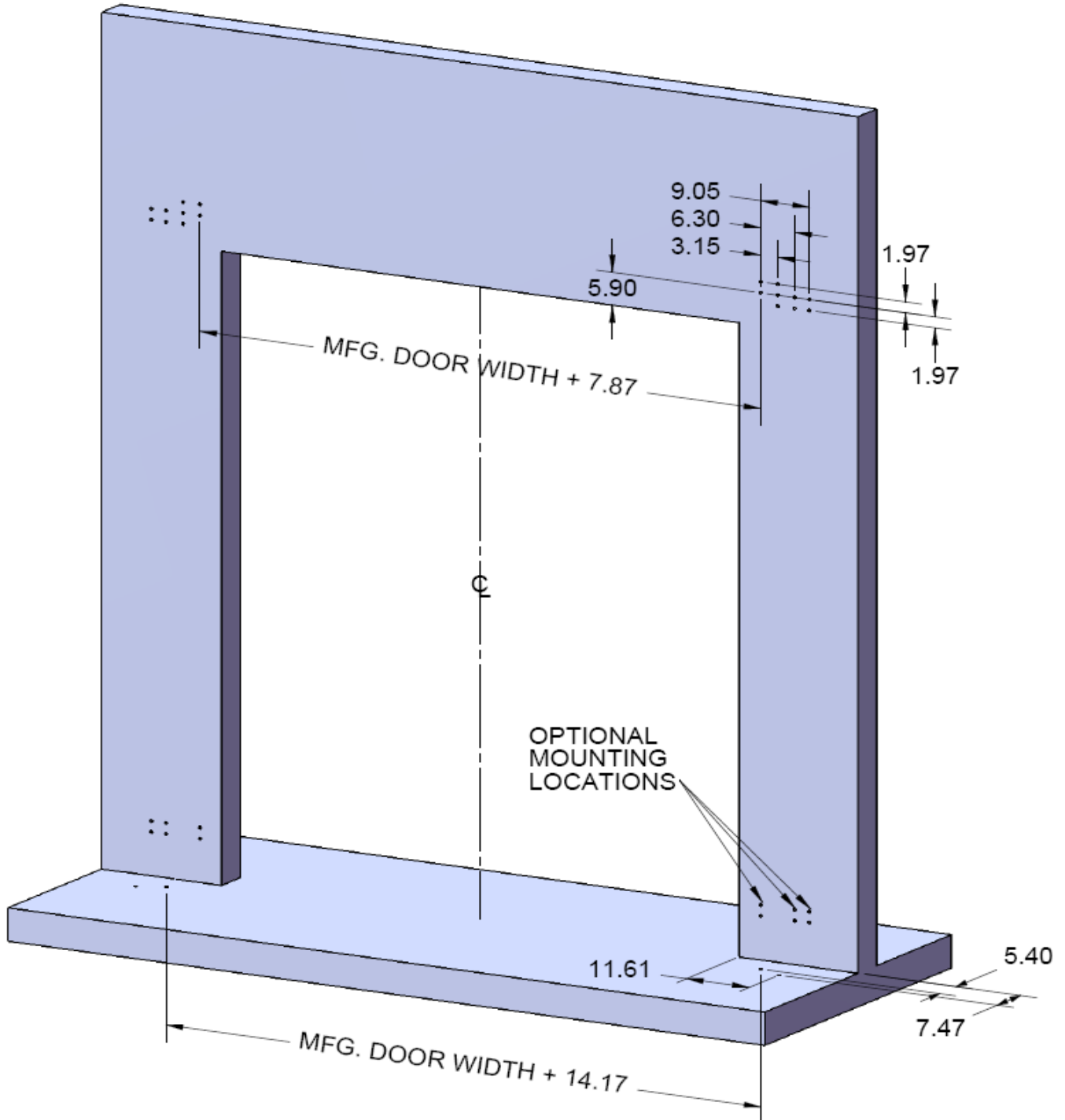

# All UltraSecure Doors

## PREPARATION FOR DOOR ASSEMBLY

Prior to door installation, the door opening must be examined to insure the existing wall construction is sufficient to support the door. For all UltraSecure Door versions, the side frames should be supported by a steel structure or concrete wall. If the door opening is insufficient to support the door a steel column or equivalent construction must be installed prior to the door installation.

Do not install the doors on insulated panel walls, honeycomb bricks or lightweight partition walls.

The door opening width and height must be checked to ensure that the door received is the same size as the opening. This can be achieved by comparing the manufactured door size listed in the corresponding door paperwork to the actual door measurements.

The door opening must be closed to all vehicle or pedestrian traffic during the installation process.

Prior to the installation the stretch wrap and/or shrink film needs to be removed from the shipping pallets. After this has occurred remove the springs and other loose door components from the inside of the side frames and place to the side until required for installation.



## MOUNTING AND DISMOUNTING

The top roll shipping pallet has two basic functions. The 1<sup>st</sup>. is as a shipping pallet or support & the 2<sup>nd</sup> is as an installation aid. Use of the fork guides is required to insure that the door does not tip or slide.

The complete side frames assemblies are located on/in a separate shipping pallet.

The Control box, drive unit and other materials for installation are located in a cardboard box, which is located in one of the shipping pallets.

## SIDE FRAME AND WIDTH GAUGE

If the door opening declines or slopes from side to side 1<sup>st</sup> attach the side frame that is located on the highest side. Both side frames must be placed at the same elevation.

Attach the side frame within the upper mounting slots provided to the wall with at least four

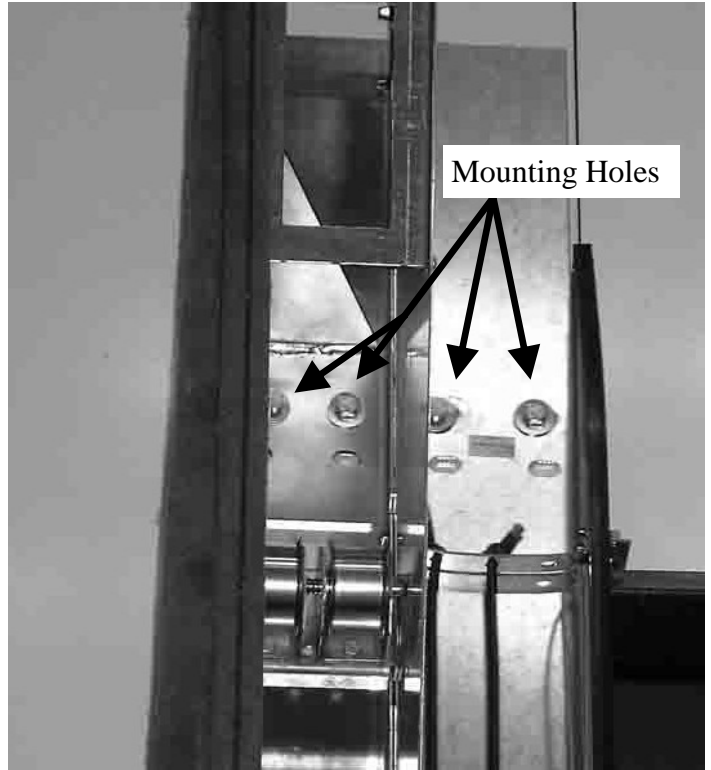

Attach the lower portion of the side frame using either the mounting slots in the back of the side frame or the holes located in the base plate. At least two bolts or screws required at this location.

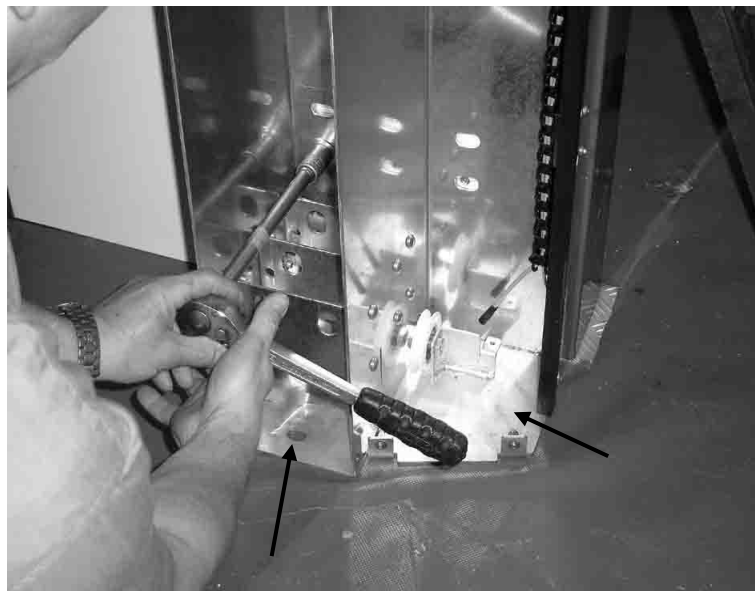

Place the second side frame on the wall and attach loosely once the width has been verified. Using the same procedures as the first side frame attach the upper portion using the provided slots. **Leave attachment screws loose until all side frame adjustments are made.**

Assemble lintel sealing profile before installing on the door. Use metal connector to join the profiles. Metal connector has a slotted hole used for wall anchoring. This bracket must be anchored.



**Double check door width by measuring between side frame black plastic wear strips. DO NOT USE THE LINTEL SEALING PROFILE TO SET THE WIDTH OF THE DOOR.**

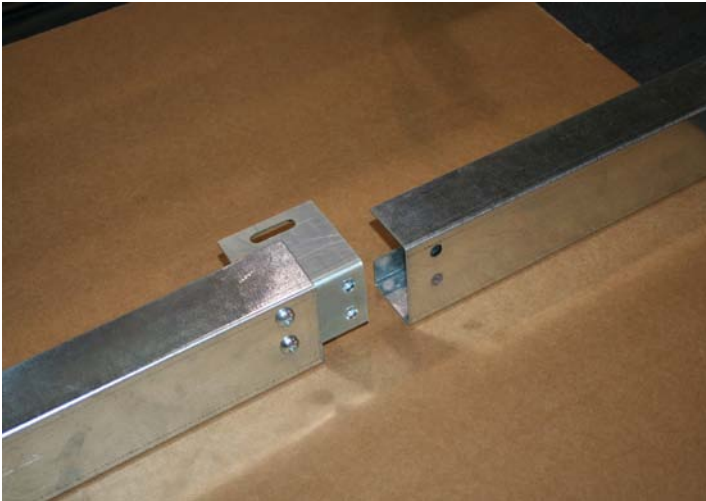

Before attaching the lower portion of the side frame verify the door opening by measuring the distance between the black plastic wear guides. This measurement should be the same as the manufactured door size. After checking the measurement verify that the door is plumb in all directions.

Attach the lower section using the same procedure as the first side frame.

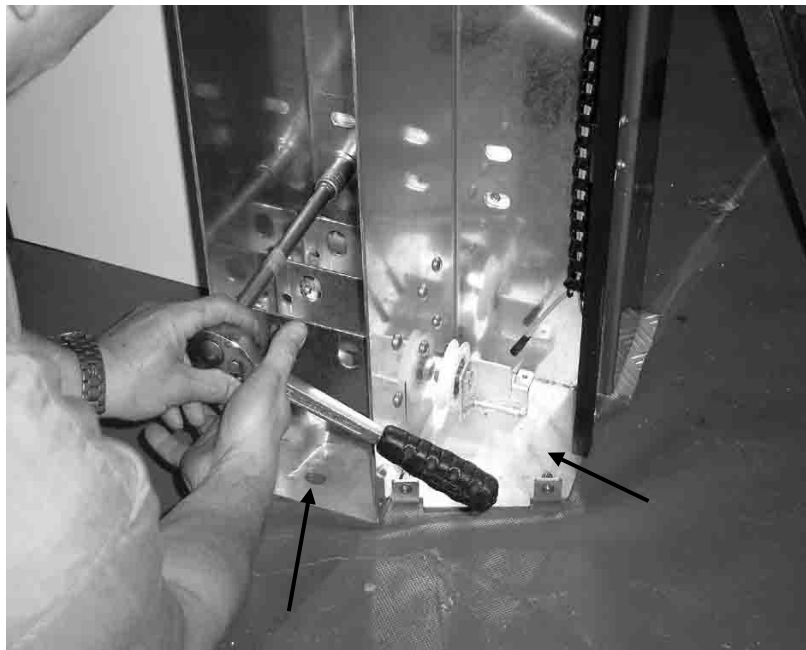

## Side Frame Alignment for Light Curtains

Ü ~ } ÁæÁ { æ • [ ] q • Á | ã } ^ Á c @ ! [ ~ \* @ Á c @ ^ Á ] ! ^ á ! ã | | ^ á Á @ [ | ^ Á ã



Þ ^ ø c Ê Á { ^ æ • ~ ! ^ Á c @ ^ Á á ã • c æ } & ^ Á ~ ! [ { Á c @ ^ Á à æ & \ Á [ ~ Á c @ ^ Á  
and far side of the frame. The frame is properly aligned when the value for both measurements is the same. If the measurements are not the same, shim the rear of the frame on the side with the higher measured value. Repeat for both frames.

Install light curtain using the pre-drilled holes. Space the light curtain off the frame using the supplied 3 fender washers with the mounting screws.

V @ ^ Á | ã \* @ c Á & ~ ! c æ ã } Á { ~ • c Á à ^ Á • ^ c Á • [ Á c @ æ c Á c @ ^ Á à [ c c [ {  
Be careful not to over tighten the screws as they can pull through the aluminium track of the light curtain.



Tighten the width gauge screws.  
The width gauge serves as a cable duct for the stationary photocells and light curtain wires.

## TOP ROLL

### DO NOT REMOVE THE PACKING STRAPS FROM THE TOP ROLL

First loosen the three screws attaching the bearing flange to the bearing plate on both sides of the barrel. This will allow for easier positioning of the roll into the side frame cradle cut out. Lift the top roll onto the side frames using a forklift, crane or other equivalent device. Position the top roll so that the center of the bearing flange is centered over the cradle cut out. Lower the roll so that the flange rests on the cradle. The two piece bearing flange sandwiches the side frame.

**3000R ONLY.** The drive unit must be installed on the top roll shaft prior to installing the top roll.

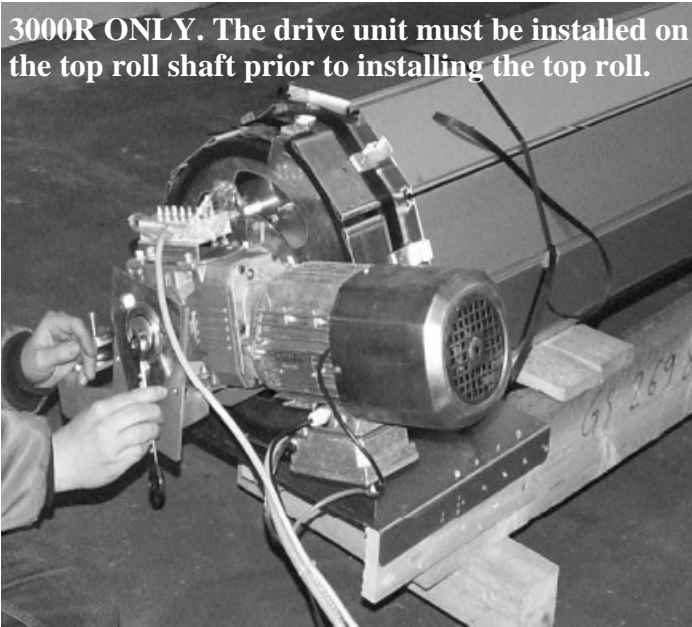

Align the point of the mounting plate with the existing hole in the side frame.

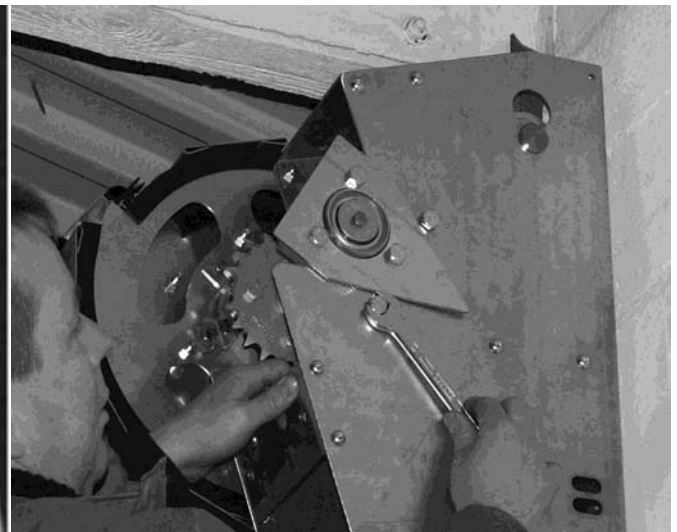
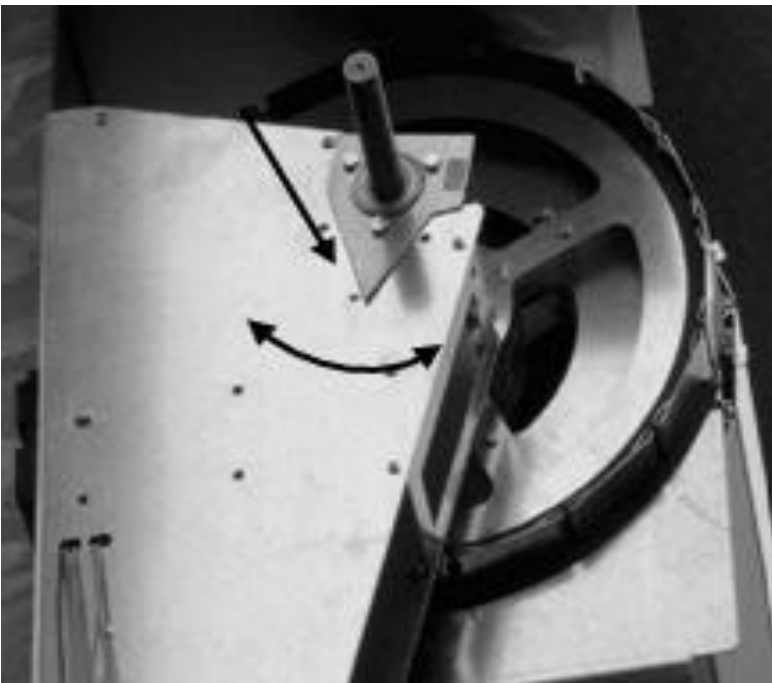

The picture at the left shows the standard and XL frame while the picture above shows the R frame.

By hand, start all three of the M10 barrel fastening screws into the bearing plate. Next, tighten the bearing flange screws loosened earlier. Tighten the remaining 3 barrel fastening screws. Repeat the process on the other side.

Once both sides are secure, the header lifting cradle can be cut away.

**When cutting away the cradle, be careful not to cut the barrel securing straps. These straps will keep the barrel wound until the gear motor assembly is installed. Cutting these straps will result in the barrel free falling.**

The barrel may begin to turn when the cradle is removed. However, the plastic straps will prevent the panel from unwinding and falling.

**If FULL ROLL COVERS were purchased, mount the motor-side full roll cover plate. Refer to the full roll cover assembly section for details. Failure to follow this step will result in lost time removing and re-installing the gear motor.**

Attach the mounting plate to the side frame with the provided M10 screws. Next tighten the three bearing flange bolts. Repeat this step for both sides of the door.

## **GEARMOTOR**

**This section applies only to the standard and XL version of the UltraSecure.**

Slide the drive unit onto the shaft of the top roll. Align the motor hollow shaft to the top roll shaft with the use of a 6mm hex key driven from below the fan guard.

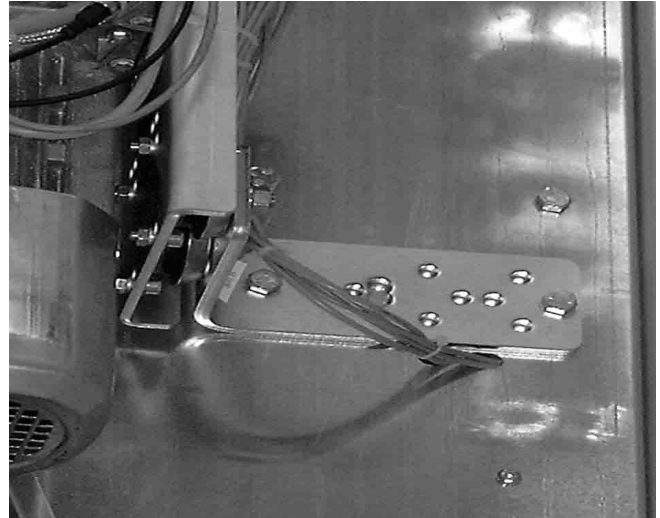

Connect the torque arm to the drive and side frame as shown.

Rotate the barrel to align the bottom slat to the side frame funnel by pulling down on the brake release handle and rotating the barrel by hand. Release the brake. You are now ready to cut the barrel straps.



---

**This section applies only to the R version.**

Release the brake to allow the motor torque arm to swing to position over the motor attachment bracket. Screw the attachment bolt through the vibration dampener until it bottoms out. From underneath the motor attachment bracket, use the nut and lock washer to complete the motor bracket assembly.

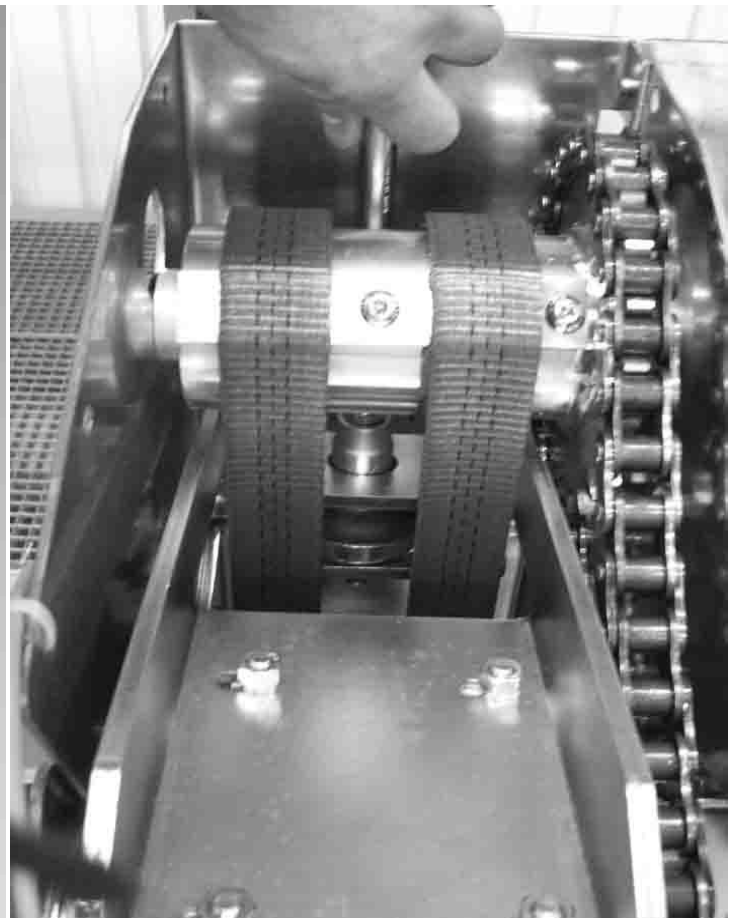
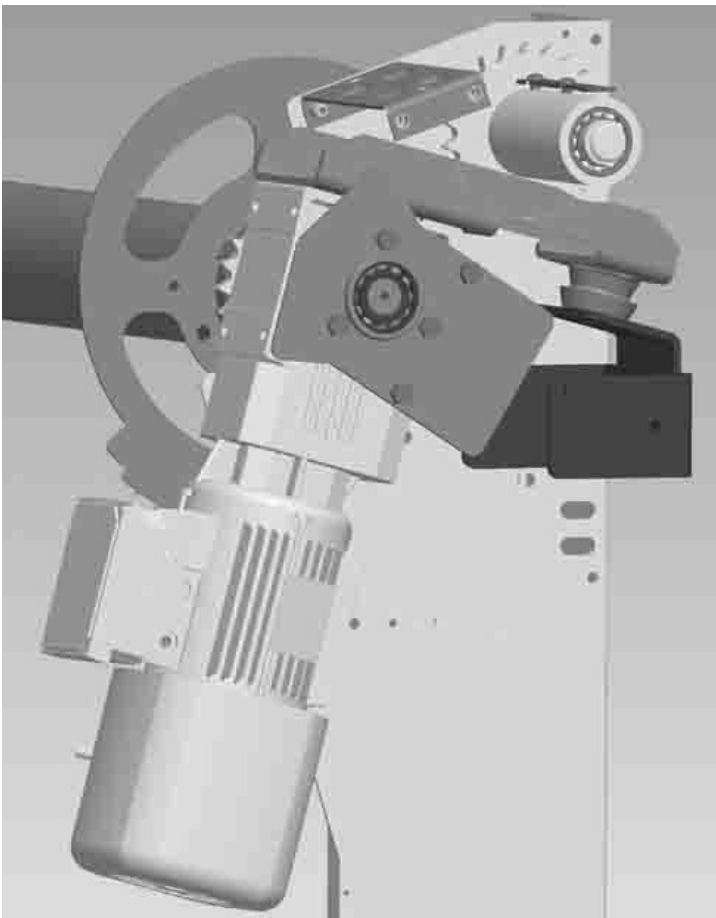

The picture to the right shows the chain connection between a drive sprocket and the counter balance belt take-up shaft. Depending on door size, some doors may have this chain driven counter-balance shaft on one side of the door and larger doors will require one on each side of the door. The tension of the chain is dependant upon the side frames being square to each other. If the chain is too loose or too tight then shimming or adjustment of the side frames may be required to provide the proper distance between the two sprockets. This chain does not have a tensioner and does not require a half link.

## COUNTERBALANCE

**This section applies only to the standard and XL version.**

Attach the counterbalance belts to the barrel under the metal bracket. Pre-wrap 2 turns of the belt in the opposite direction that the curtain will roll up.

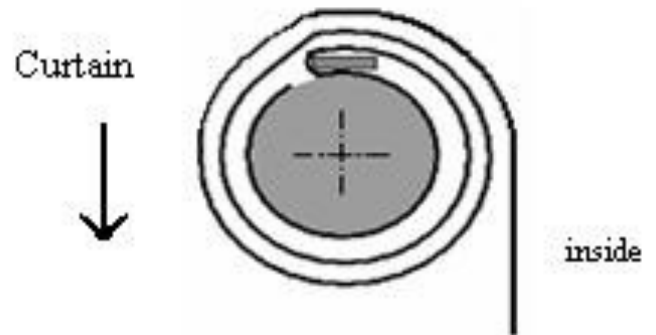
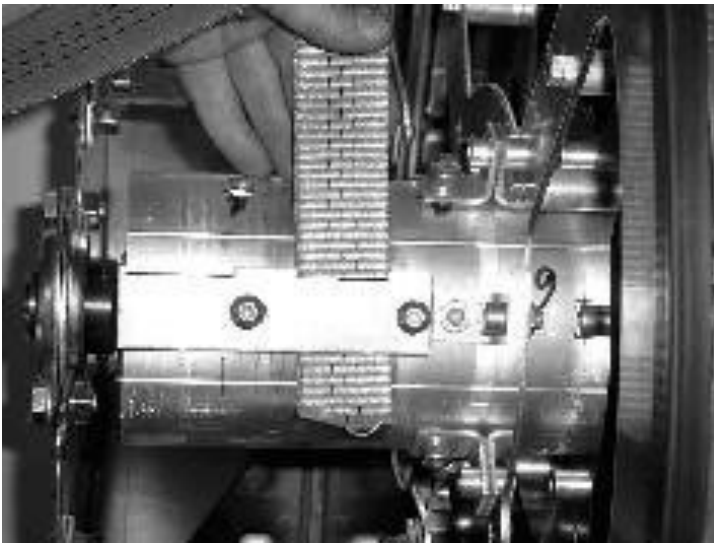

Run the counterbalancing belts behind the idler pulleys and down the side frames. Please note that the belt must run flat against the pulley & free of any twisting.

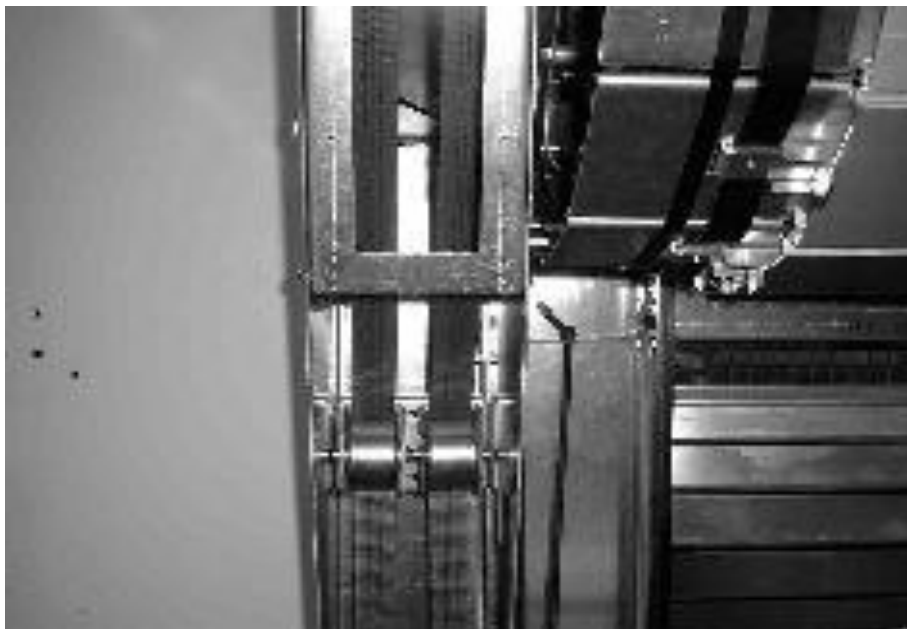

**COUNTERBALANCE**

**This section applies only to the R version.**

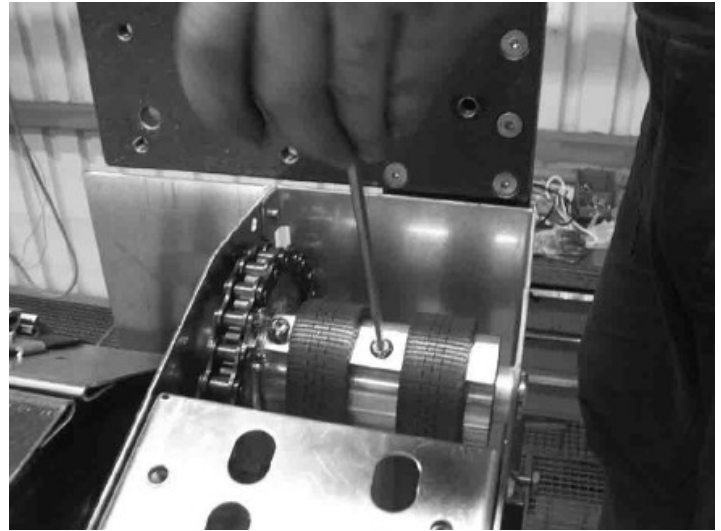
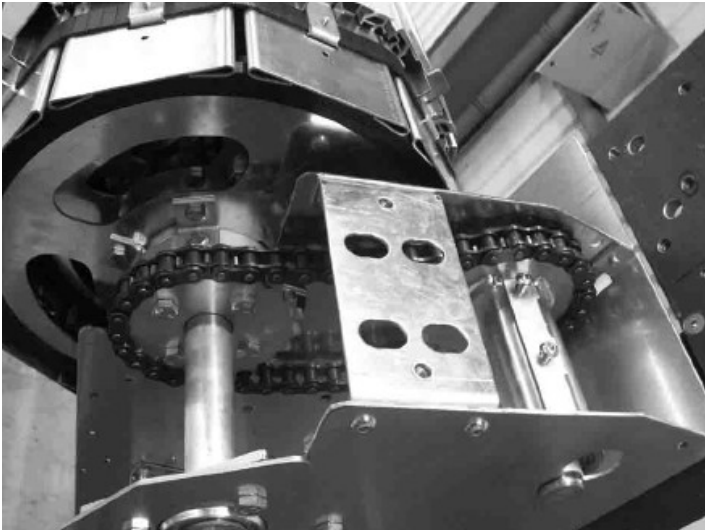

Attach the counterbalance belts to the barrel under the metal bracket. Pre-wrap 2 turns of the belt in the opposite direction that the curtain will roll up. Secure the belt by tightening the clamp plate screws.

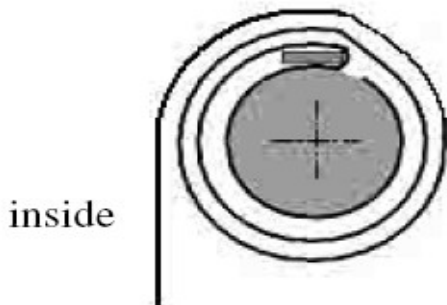
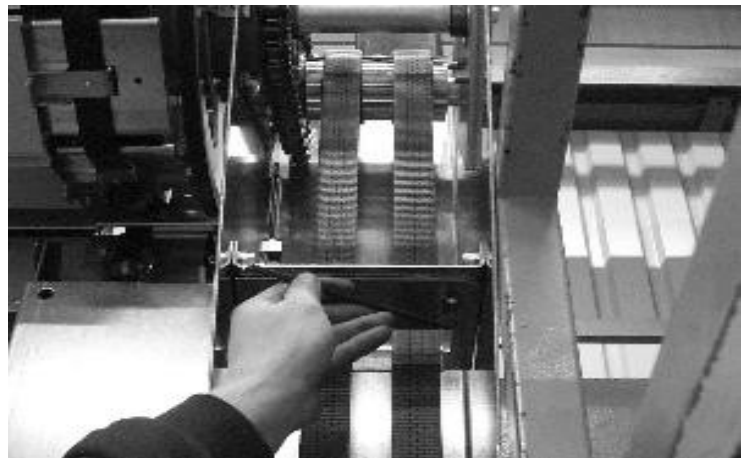
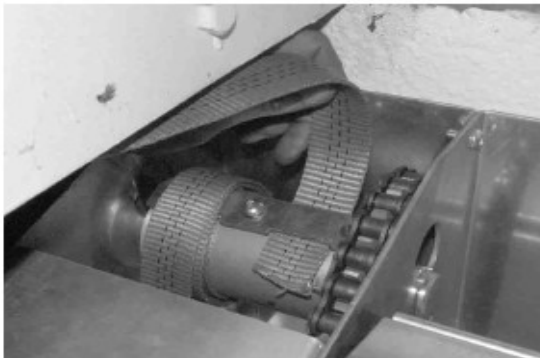

Adjust the belt guide so that with the door open, the funnel edge is just off of the belt.

Run the counterbalance belts through the upper spring attachment bracket.

With the door in the open position add the appropriate pre stretch to the spring length and set the upper spring bracket at this location.

DH ≤ 2000mm Ç ĩ ì Èè Ğ + D Ā -stretch ĩ ^  
 DH > 2000mm Ç ĩ ì Èè Ĩ + D Ā -stretch ĩ ^

Hang the springs in the upper spring attachment brackets then stretch the springs down and attach to the lower brackets.

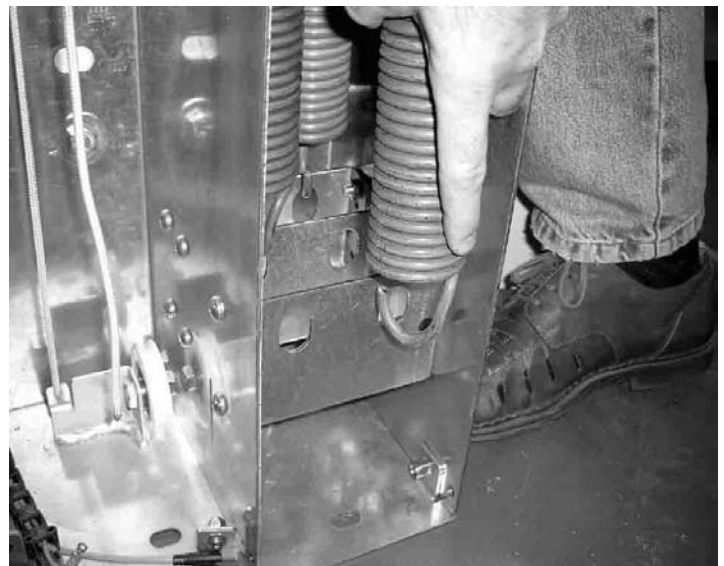

---

## **Bottom Lift Strap Assembly**

---

Attach the lift belt to Adapter 4 by wrapping the lift belt under the adapter and passing the M5 x 20 screw through the front and back holes of the belt. The washer is placed on the front and the threaded belt clamp is positioned behind. Use the fender washers provided. Repeat for both sides.

## Top position proximity switch

The position of the top position proximity switch (1) is adjustable by loosening screw (2) and sliding the prox thru the slotted hole to obtain a

**NOTE:** The standard 3000 and XL models have a prox orientation of vertical as shown to the right and the 3000R has a horizontal orientation as shown below. Either orientation requires adjustment.

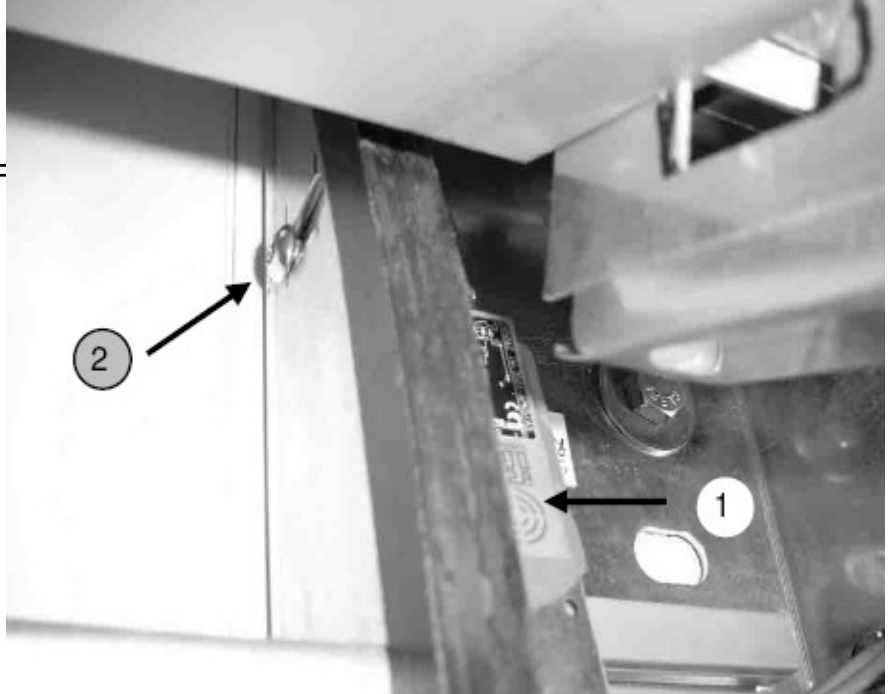

## BRAKE RELEASE CABLE ROUTING

Create a loop with 1 of 2 cable clamps supplied and hook the loop to the brake release handle spring.



On the **R model** thread the inner cable thru the small hole in the belt guide plate and pull all the slack thru.

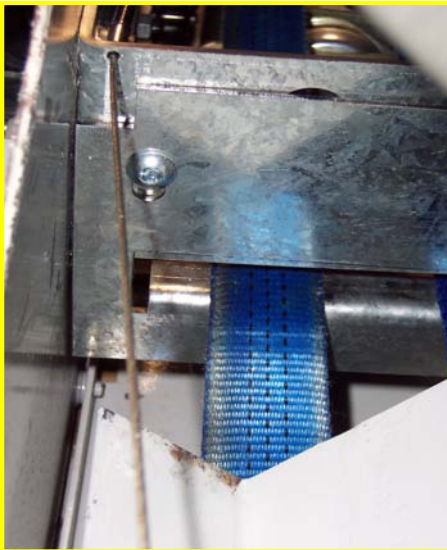

On the **Std and XL models** the inner cable will thread thru the top support plate as shown and pull all the slack thru.

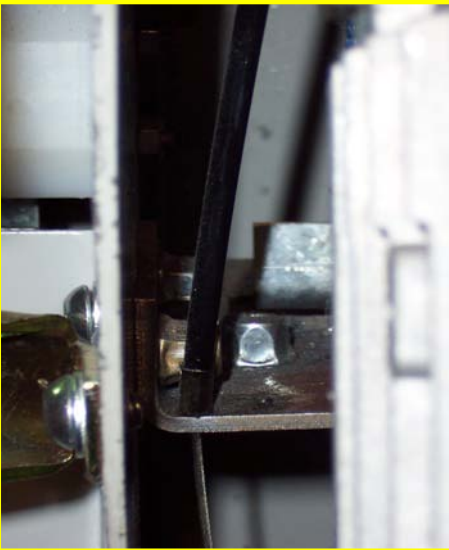
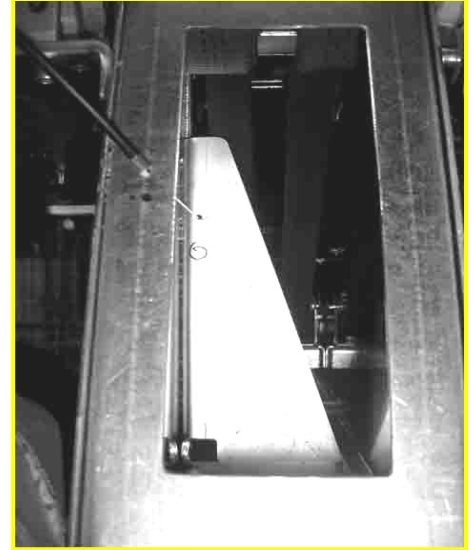

Once the slack of the inner cable is pulled thru you will now thread on the outer sheath making sure to include the ferrules on both ends of the sheath.



Now thread the inner cable down thru the brake release rod and pull the inner cable all the way thru until the outer sheath butts up to the brake release rod.



Now loop the cable thru the grid on the fan shroud and pull all the slack thru. Tighten the cable clamp to retain the cable at this point.

Proper operation of the brake release will allow for the outer sheath to push down on the brake release rod of the motor. Slight tension adjustments of the cable may be required. Once adjusted, cut the cable excess leaving 4 or more inches.

***Use caution when pulling the brake release so as not to allow the door curtain to travel out of the top of the guides.***

## SIDE FRAME COVERS

Install the cover gussets using the appropriate slots located in the side frame (**Standard and XL** configuration only).



Attach the outer covers using the appropriate slots located in the side frame and the provided hardware. It may be necessary to push the cover toward the door blade to start the screws. Use care not to cross thread the compression nut inserts. It is critical to have a smooth transition between the upper and lower plastic rails.



*H \ Y ' [ U d ' V Y h k Y Y b ' h \ Y ' d ' U g h ] W ' f U ] ` g ' / ' h \ Y ' W i f h U ]*



The **R model** does not have an inner cover gusset as above. It only has a one piece outer cover. The bolting flange of the cover has slotted holes to allow for cover adjustment. There is also a reinforcement gusset at the top of the cover that will need to be

The **XL model** has an additional outer cover that has slotted holes in the bolting flange which allows for the gap adjustment to be made as shown below.



bolted in place as well. Use care not to cross thread the compression nut inserts. High impact tools are not recommended for installing these bolts.

Install the side frame spring box covers with the provided hardware.

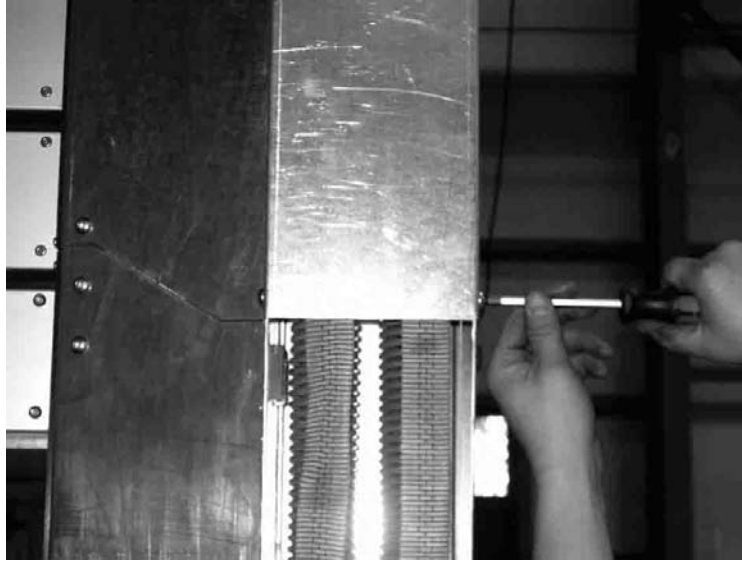

### **Front mounted light curtains (if applicable)**



Mount light curtains to the bracket on the side frame using two M4 screws supplied with the light curtains. Plug the light curtain cable into the supplied M12 cable.



## FULL ROLL AND MOTOR COVERS

**These instructions pertain to the Standard and XL versions only.**

Install the side cover (1) assembly before mounting the drive unit. After the remaining installation is completed install the front cover (3) and the top cover (4) with the provided hardware.

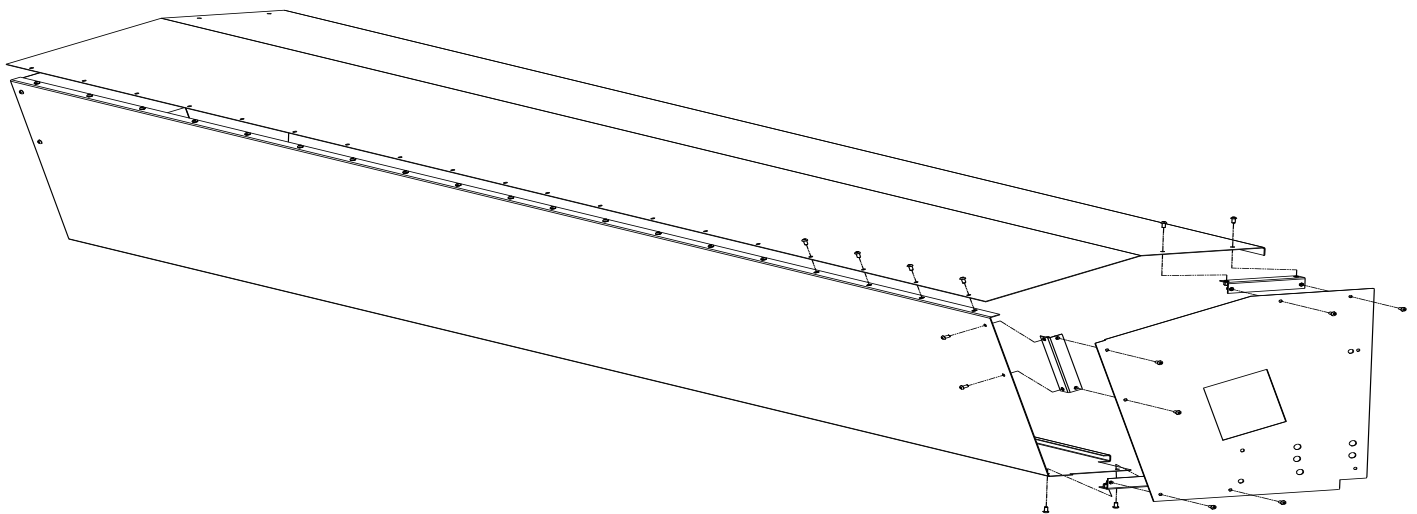
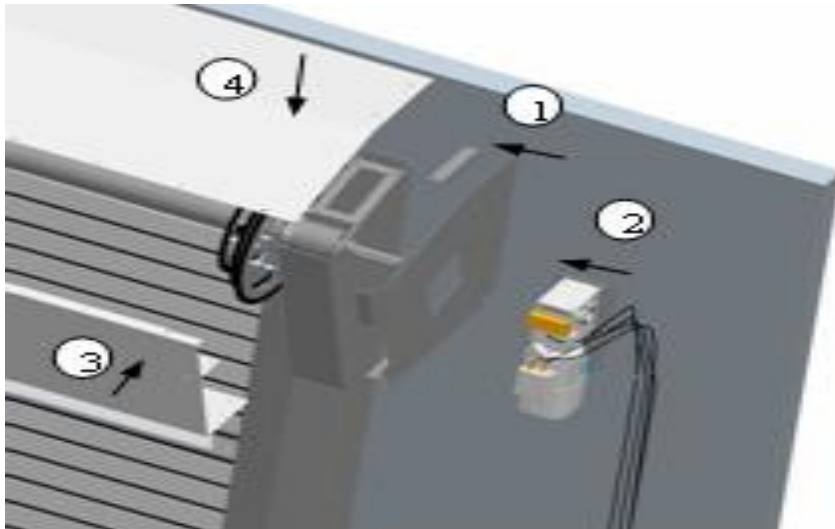

Using the hardware provided install the motor cover back to the side plate (1). Next install the bottom cover (2), then the front cover (3), and finish by installing the top cover (4).

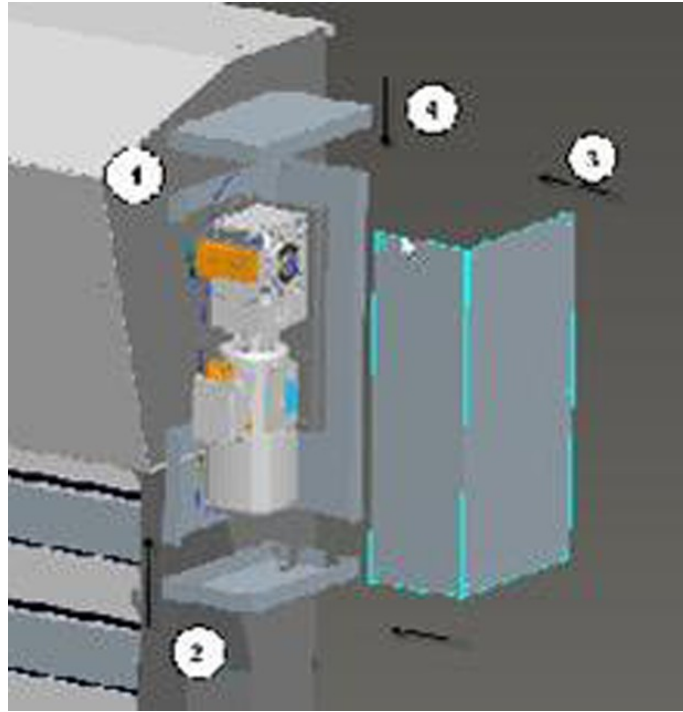

**These instructions below pertain to the 3000R version only.**

Install the support plates of the top roll cover at the side frames. Next attach the front cover followed by the top cover.

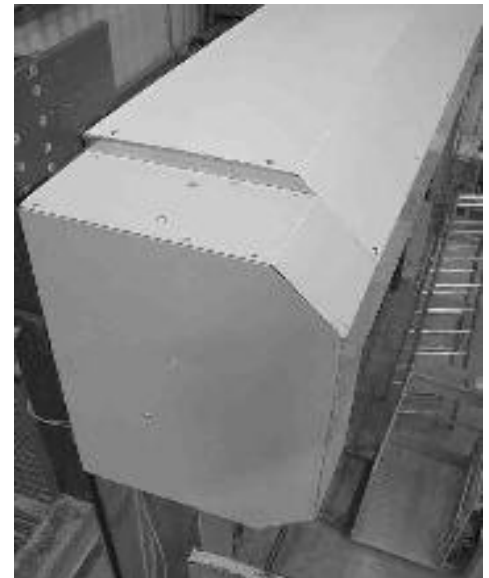
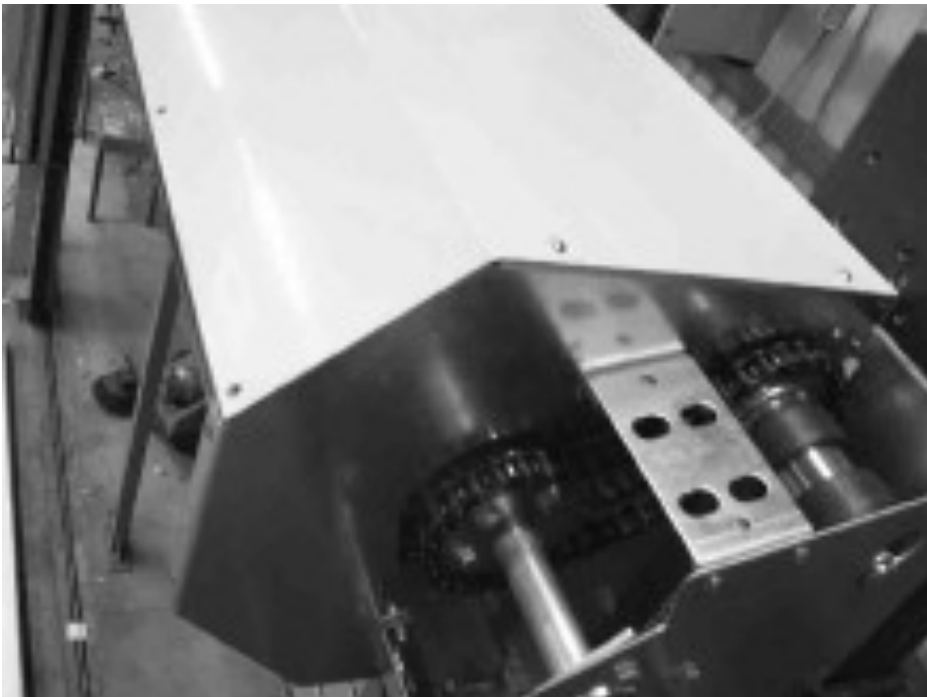

Install the motor cover.



# Installation Checklist

*Please fill out below and return to Albany Door Systems*

Customer \_\_\_\_\_  
Location: \_\_\_\_\_  
Contact: \_\_\_\_\_  
Install Company: \_\_\_\_\_

Installation Date(s): \_\_\_\_\_  
Door Serial #(s): \_\_\_\_\_  
Contact Phone #: \_\_\_\_\_  
Contact & Phone #: \_\_\_\_\_

## Mechanical Installation (All Doors)

**Yes**      **No**

Is the door secured to the wall using thru-bolts?

\_\_\_\_\_

If No, what type of anchor was used?

\_\_\_\_\_

Are the door roll and rear spreader level?

\_\_\_\_\_

Are the side columns plumb?

\_\_\_\_\_

Does the door have counterweights or springs?

\_\_\_\_\_

If Yes, are the straps routed properly?

\_\_\_\_\_

Is the door caulked or sealed to the wall?

\_\_\_\_\_

Are there any visible gaps between the door and the wall?

\_\_\_\_\_

If No, did the customer contact approve of door to wall seal?

\_\_\_\_\_

Is there any visible damage to the door?

\_\_\_\_\_

If Yes, what is the damage?

\_\_\_\_\_

Was Customer Service notified of the damage?

\_\_\_\_\_

Was the customer contact notified of the damage?

\_\_\_\_\_

| <b>Electrical Installation</b>  | <b>Yes</b> | <b>No</b> |
|---|------------|-----------|
| Were the factory supplied cables (motor, encoder & 7-wire) long enough? | _____      | _____     |
| If No, which cables were too short?                                     | _____      |           |
| If No, was Customer Support contacted and new cables sent?              | _____      | _____     |
| Were the schematics easy to read for electrical hook-up?                | _____      | _____     |
| What type of conduit was used to route the cables to the door?          |            |           |
| Is the conduit routed to the bottom of the control box?                 | _____      | _____     |
| If No, did the customer approve this?                                   | _____      | _____     |
| If No, why?   | _____      |           |
| _____   |            |           |
| _____   |            |           |
| If Yes, who was the customer contact that approved?                     | _____      |           |

**Door Start-Up**

**Yes**

**No**

Was the door start-up procedure easy to follow?

\_\_\_\_\_

\_\_\_\_\_

If No, what problem(s) did you run into?

\_\_\_\_\_

\_\_\_\_\_

\_\_\_\_\_

Was Customer Support notified of these issues?

\_\_\_\_\_

\_\_\_\_\_

Is the Reversing Edge working?

\_\_\_\_\_

\_\_\_\_\_

Are the front and rear light curtains (or photo-eyes) working?

\_\_\_\_\_

\_\_\_\_\_

Do the bottom bar breakaway switches work?

N/A

\_\_\_\_\_

\_\_\_\_\_

Does the repair feature work when the door is broken away?

N/A

\_\_\_\_\_

\_\_\_\_\_

If the door has counterweights or springs, does the egress work?

\_\_\_\_\_

\_\_\_\_\_

---

**Activation**

**Yes**

**No**

What type of activation is being used? \_\_\_\_\_

Was the activation supplied by Albany Door Systems? \_\_\_\_\_

Did the customer approve of the mounting and operation of the activators?

**Comments**

---

---

---

---

***Please email digital pictures of the installed door to: [support@albint.com](mailto:support@albint.com)***

| Inspection Plan  |                                  |
|--|----------------------------------|
| Observe the safety notices within the operation manual. Power to the door must be shut inspection of any door component. |                                  |
| Installation fixings   |                                  |
| spring housing and eventually the existing top roll and motor cover must be dismantled.                                  | Annually or 100,000 cycles.      |
| Drive unit   |                                  |
| Check retainer of the torque support and buffer.   | Annually or 100,000 cycles.      |
| Check function of brake release lever.   | Annually or 100,000 cycles.      |
| Check self-opening/manual opening/egress   | Annually or 100,000 cycles.      |
| Drive shaft  |                                  |
| Check flange bearing retainers of drive shaft.   | Annually or 100,000 cycles.      |
| Check retainer of the spiral disk on the shaft.  | Annually or 100,000 cycles.      |
| Check condition of sound isolation or black dampener profiles on the spiral disks.                                       | Annually or 100,000 cycles.      |
| Exchange of flat lifting belts.  | 500,000 cycles.                  |
| Door leaf  |                                  |
| Check surface of lamellas/slats for grinding and signs of damages.   | Annually or 100,000 cycles.      |
| Check exact position of lamella sealing.   | Annually or 100,000 cycles.      |
| Check fixing of lamellas on pulling device.  | Annually or 100,000 cycles.      |
| Check solid position of lamella adapter/endplates.   | Annually or 100,000 cycles.      |
| Guiding rails  |                                  |
| Check for wear and tear on guiding rails, especially in the area of funnels.   | Annually or 100,000 cycles.      |
| Side columns and lintel profile  |                                  |
| Check fixing and condition of the profiles as well as fixing at the wall.  | Annually or 100,000 cycles.      |
| Check condition and fixing of trailing chain for cable if equipped   | Annually or 100,000 cycles.      |
| Check condition and installation of springs and spring fixing.   | Annually or 100,000 cycles.      |
| Check leaf tensioning system if equipped.  | Annually or 100,000 cycles.      |
| Exchange rubber cable/bungee cord if equipped  | 500,000 cycles.                  |
| Clean optic of photocells.   | As necessary.                    |
| Counter balance system   |                                  |
| Exchange springs H<3m.   | 500,000 cycles.                  |
| Exchange springs H>=3m.  | 250,000 cycles.                  |
| Check condition and fixing of the spring belts.  | Annually or 100,000 cycles.      |
| Lubrication of roller chain (only RR3000R).  | Annually or 100,000 cycles.      |
| Control Box and additional components (like safeties & actuators)  |                                  |
| Check completeness of wiring diagram.  | Annually                         |
| Check main switch/CEE-plug and control box lock.   | Annually                         |
| Check fixing of control panel  | Annually                         |
| Check function of stationary and/or pre-running photocells   | Every 6 months or 25,000 cycles. |
| Verify stopping position of limits   | Annually or 50,000 cycles.       |
| Check function of electric reversing edge if equipped  | Every 6 months or 25,000 cycles. |



Albany Door Systems - A Company of Albany International Corp. All Rights Reserved  
1080 Maritime Drive, Port Washington, WI 53074 - 975-A Old Norcross Road, Lawrenceville, Georgia 30046  
262-268-9885 [www.albanydoors.com](http://www.albanydoors.com)