

## MOTOR WIRING

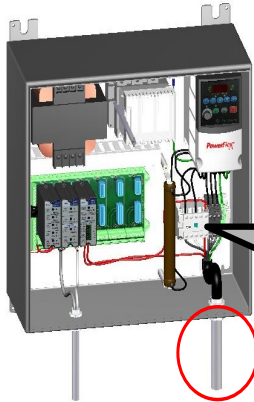

MOTOR WIRE CONDUIT

DRILL ONLY INTO BOTTOM OF BOX  
USE MINIMUM 3/4" CONDUIT

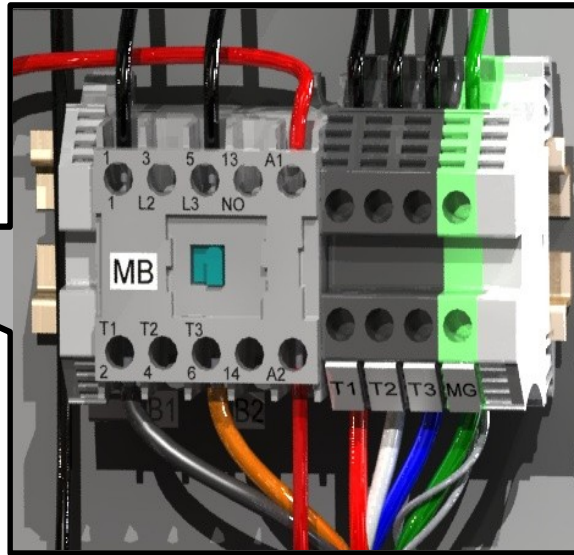

## WIRE STRIP GAUGE

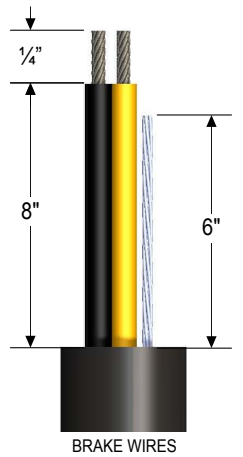

BRAKE WIRES

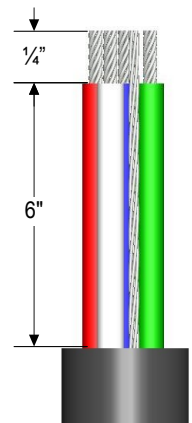

MOTOR WIRES

	WIRE	TO TERMINAL
SEPARATE FOIL SHIELD	RED	T1
	WHITE	T2
	BLUE	T3
	GREEN	MG
	BARE SHIELD DRAIN	MG
SEPARATE FOIL SHIELD	BLACK	B1
	ORANGE	B2
	BARE SHIELD DRAIN	MG

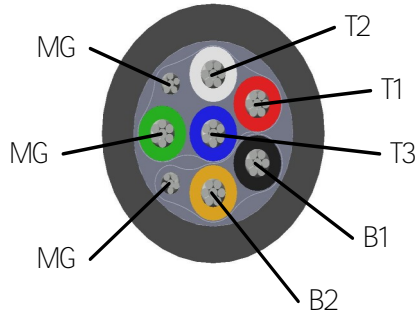

NOTE: TO CHANGE DIRECTION OF MOTOR ROTATION – SWITCH T1 AND T2

## ENCODER WIRING

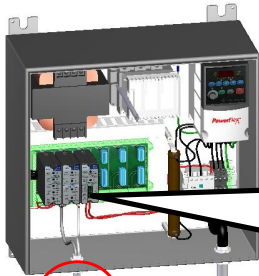

3/4"

LOW VOLTAGE CONDUIT  
ENCODER, SAFETY, ACTIVATION

DRILL ONLY INTO BOTTOM OF BOX  
USE MINIMUM 3/4" CONDUIT

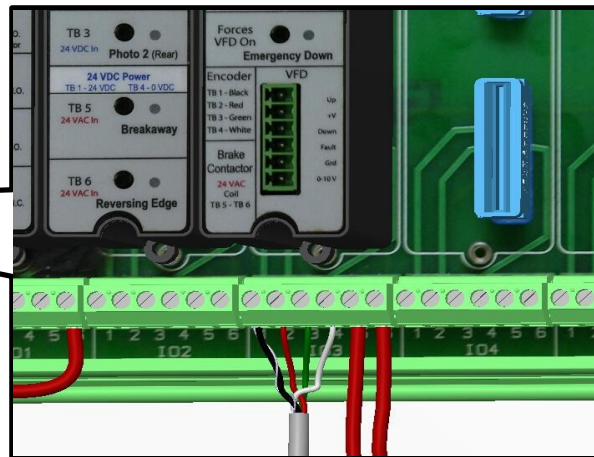

## WIRE STRIP GAUGE

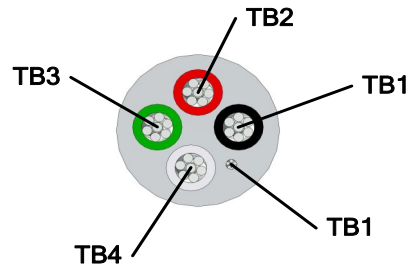
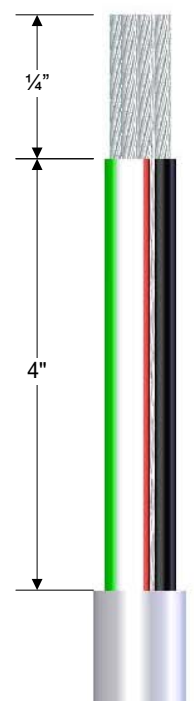



**ACTIVATION WIRING**

N TOP 3 TERMINALS  
 H NEXT 5 TERMINALS

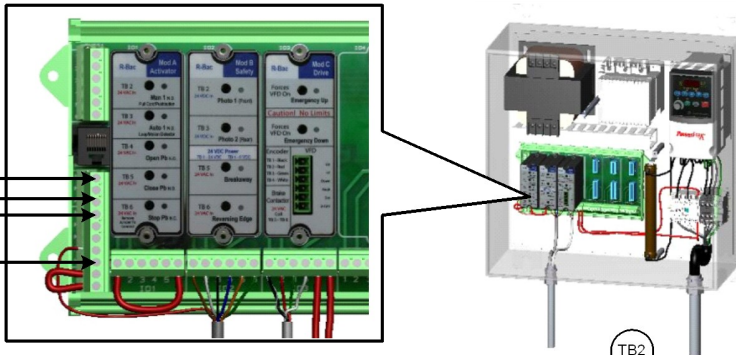

**MANUAL ACTIVATORS**  
 CONNECT AS "NORMALLY OPEN"

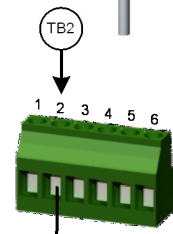
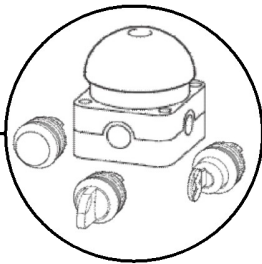

**HERKULES™ MOTION SENSOR**

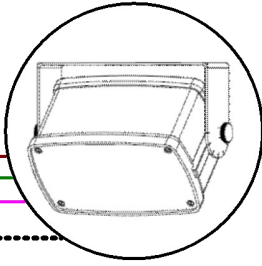

Connect GRAY for Person Detection  
 GRAY  
 RED  
 Connect RED for Vehicle Detection

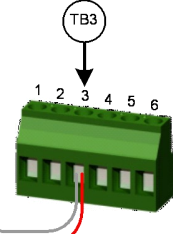

**FALCON™ MOTION SENSOR**

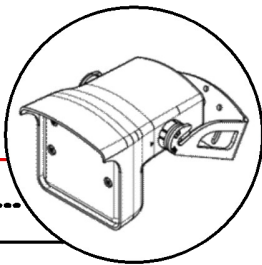
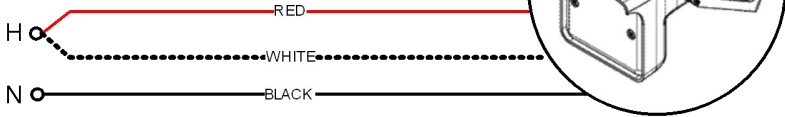

GREEN

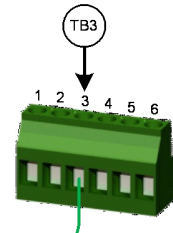

**REMOTE CONTROL**

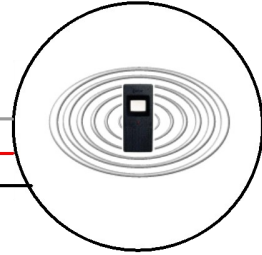
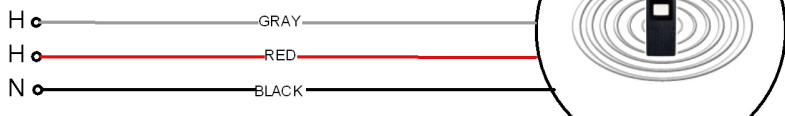

GRAY

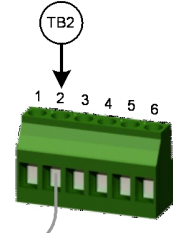

**LOOP DETECTOR**

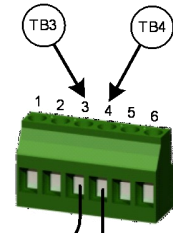
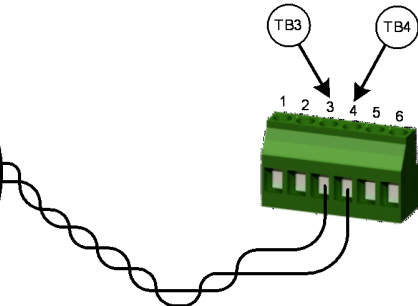
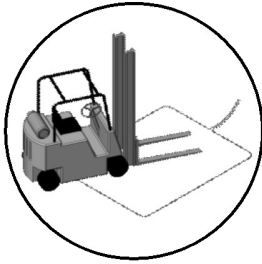

(optional)

## DEFROST WIRING

Albany doors may be equipped with one of the following optional systems:

- Heated Blowers
- IR Lamps
- IR Lamps & Unheated Blowers
- Unheated Blowers

Use **18AWG** or larger wires for all connections to **RED** terminal blocks. Use **12AWG** or larger wires for all connections to **BLACK** terminal blocks.

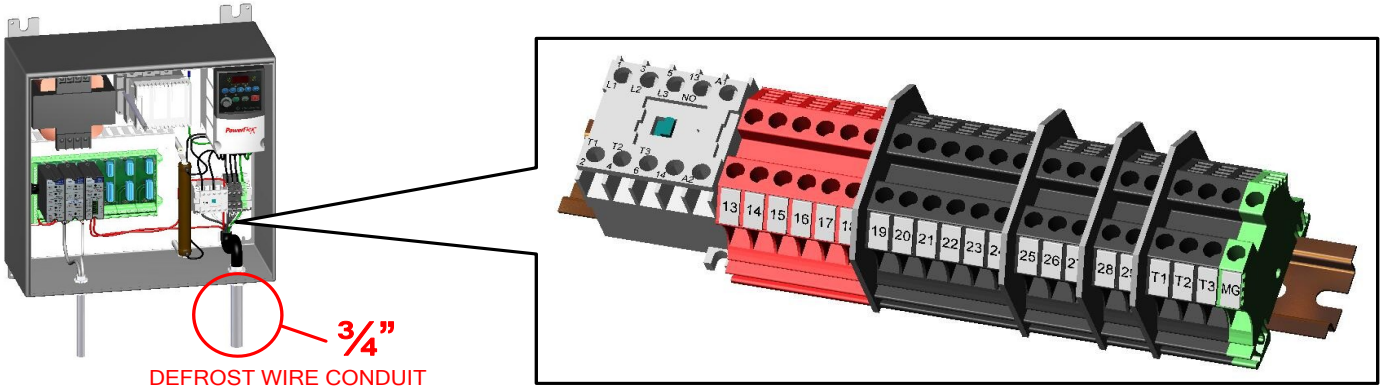

*DRILL ONLY INTO BOTTOM OF  
BOX  
USE MINIMUM 3/4" CONDUIT*

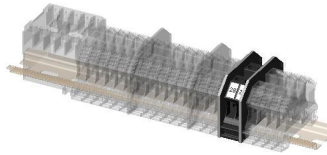

CONNECT TERMINALS 28 & 29  
TO 120VAC HEAT TAPE  
LOCATED IN JUNCTION BOX ON HEADER

